

Basaltex 

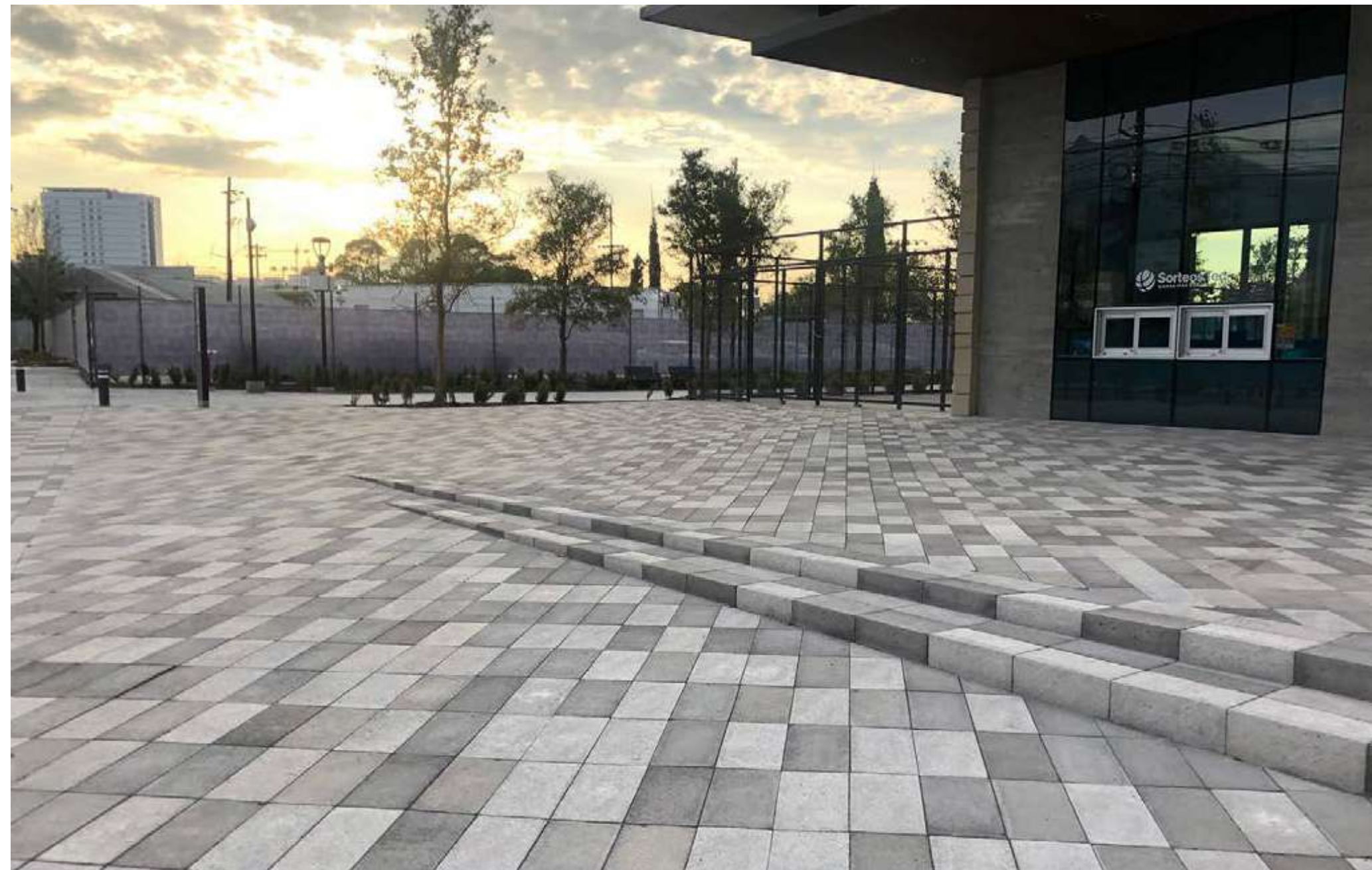

CATÁLOGO DE PRODUCTOS



- 4. Tabla de contenidos
- 6. Somos Basaltex
- 8. Usos
- 10. Colores y texturas
- 16. EcoBas

- 18. Pisos de concreto
- 30. Cintilla
- 34. Celosías
- 42. Guarniciones
- 48. Huellas y escalones

- 54. Muebles urbanos
- 62. Ideas en concreto
- 70. Adocretos



TABLA DE CONTENIDOS



SOMOS BASALTEX



Basaltex

Somos una empresa mexicana con más de 20 años de experiencia, pionera en la fabricación de elementos de concreto y líderes en la innovación de una gran variedad de productos e "ideas en concreto" losas, losetas, celosías, guarniciones, elementos pre-colados, mobiliario urbano, entre otros elementos de alta calidad, gran durabilidad, garantía de producción y entrega a gran escala.

La gran experiencia de nuestro equipo de trabajo en el ámbito del diseño, de la construcción y trituración, así como en el aspecto técnico en la elaboración del concreto y fabricación de nuestros productos, se amalgama con la utilización de tecnología alemana y materias primas de excelentes características que garantizan alta calidad desde el origen hasta el producto terminado.

Participamos en proyectos y obras de notable trascendencia; Plazas públicas, calles y avenidas (Paseo de la Reforma en la Ciudad de México), parques, malecones (Mazatlán, Acapulco), equipamientos de transporte (Metrobús en la Ciudad de México), de educación (ITESM, UDEM.), de cultura (Museo Tecnológico de la Ciudad de México), obras habitacionales, entre muchas más, tanto en el sector público como privado, son muestra de la confianza de nuestros clientes y de la solidez de nuestra marca.

TRÁNSITO LIGERO

Conjuntos de casas residenciales
(vialidades)
Pasillos
Plazuelas
Centros comerciales
Plazas
Parques

TRÁNSITO PESADO

Pisos para instalaciones febriles	Siderúrgicas
Rampas,	Talleres
Estacionamientos,	Laboratorios,
Patios de maniobra,	Lineas del metro y vialidades.
Explanadas,	Parques
Accesos a tránsito vehicular pesado	

TRÁNSITO PEATONAL

Andadores
Plazuelas
Jardines
Camellones
Pasillos
Asoleaderos
Terrazas
Banquetas

TRÁNSITO MEDIO

Bodegas
Talleres
Pisos para industrias ligeras
Hospitales
Deportivos
Escuelas
Hoteles
Bancos

**USOS**

COLORES Y TEXTURAS



COLORES

Los colores y texturas presentados a continuación aplican para todos nuestros productos.



NEGRO **BASALTO**

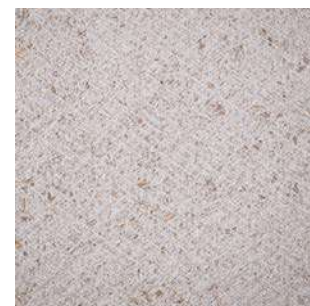

BLANCO **ACAPULCO**



EGADE



ROSA MITA

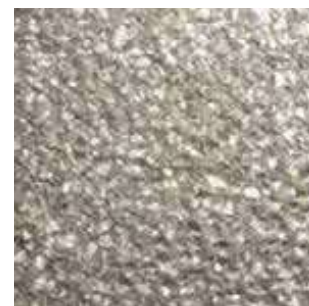

GRIS **BICENTENARIO**



GRIS **CALIZA**



REFORMA



AMARILLO **GFA**



GRIS **LH**

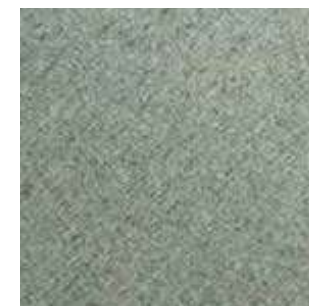

VERDE



ROJO **PÓRFIDO**



SIQUEIROS



NEGRO **INTENSO**



BLANCO



GRIS **BKR**



OCRE



ROJO **TEC**



GRIS **UD**



CAFÉ **870**



ARENA **LH**

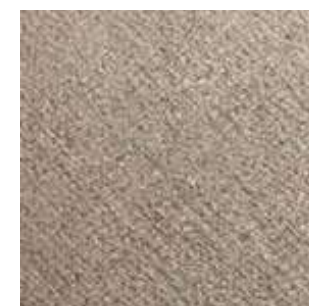

BTCH

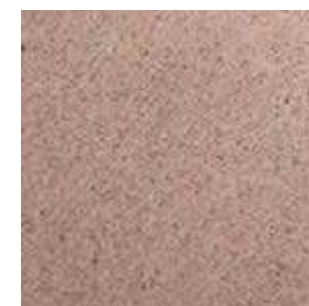

DURAZNO



PAJA



NEGRO **ALM**

TEXTURAS

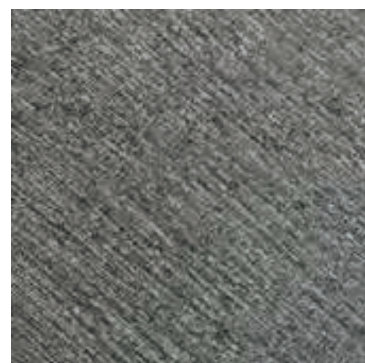

MAQUINEADA



LISA

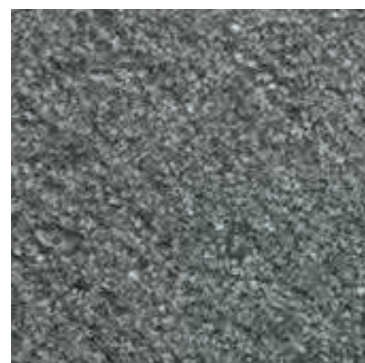

PERREADA



PULIDA

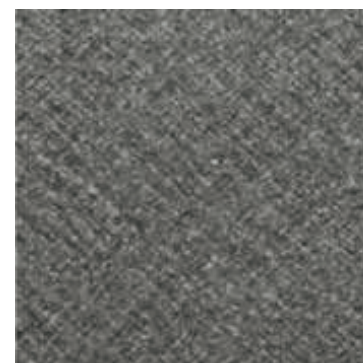

DOBLE MAQUINEADA



PUNZONEADA



DOBLE PERREADA

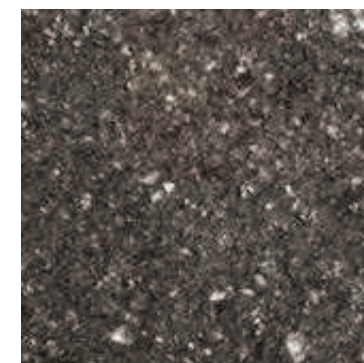

AL ÀCIDO

ECOBAS



El nuevo producto de Basaltex es ECOBAS. Un aditivo que agregado a nuestros productos genera un proceso fotocatalítico capaz de descontaminar sustancialmente el aire y genera mediante oxidación compuestos naturales que benefician el desarrollo de áreas verdes. ECOBAS se incorpora en pisos, mobiliario urbano, celosías, guarniciones, entre otros.

APLICACIONES

Es ideal para ser aplicado en fachadas de edificios, pavimentación de calzadas, plazas, explanadas, áreas de ocio y banquetas de calles cercanas al tráfico intenso.

BENEFICIOS

La tecnología permite reducir la contaminación atmosférica. Posee además propiedades bactericidas, fungicidas, desodorantes y antiestáticas (anti-polvo).

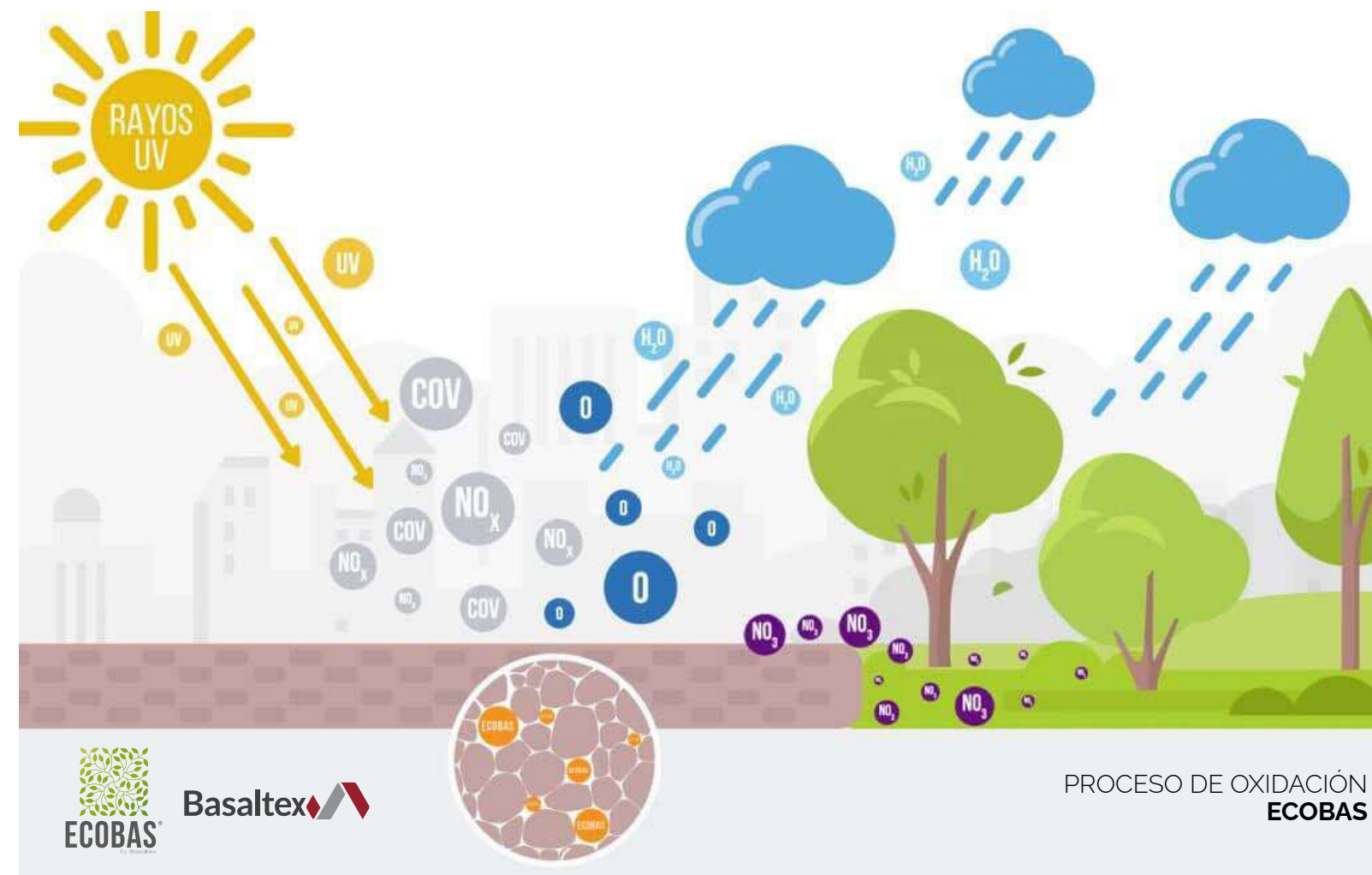

PISOS DE CONCRETO

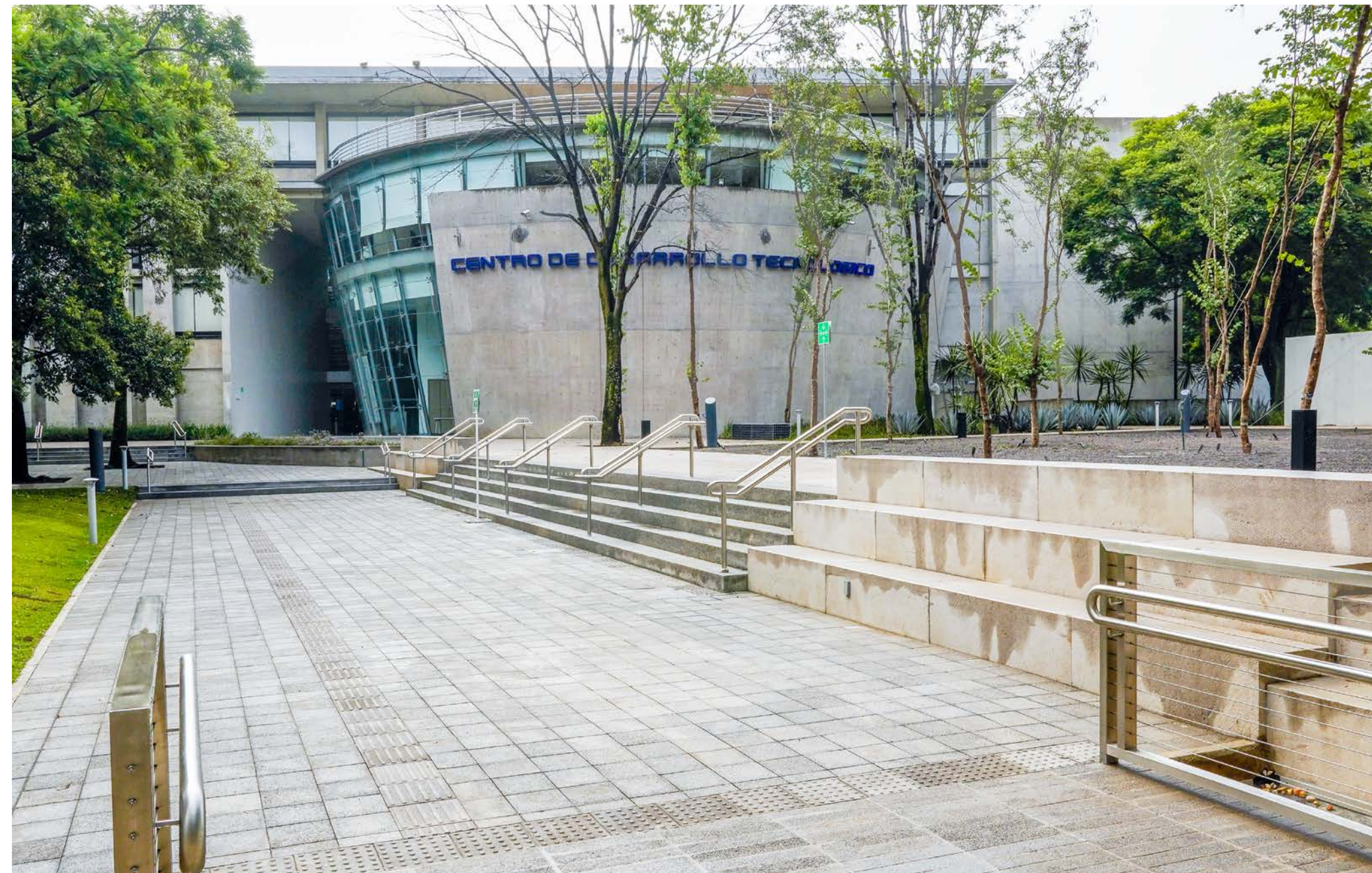

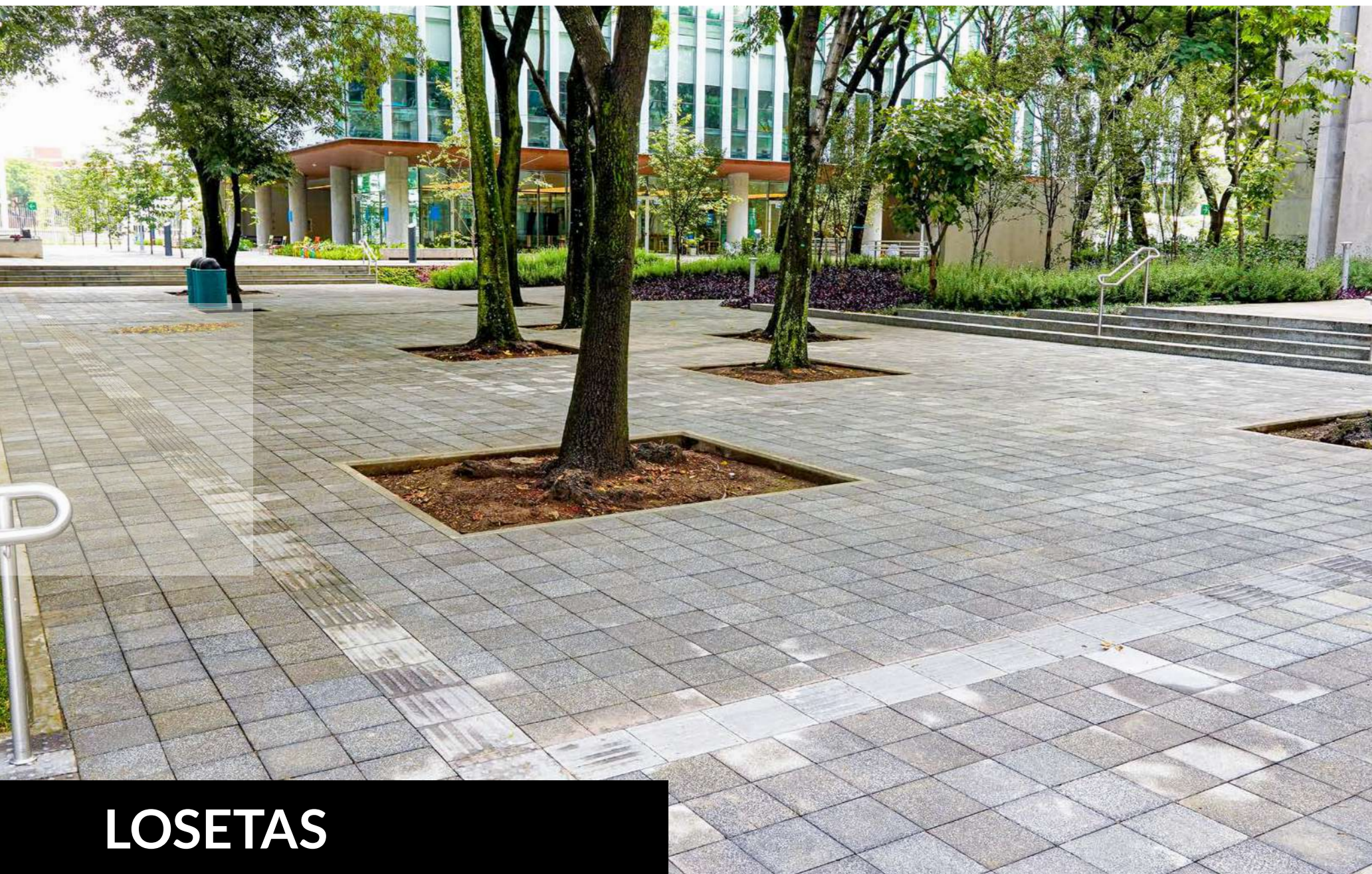

LOSETAS

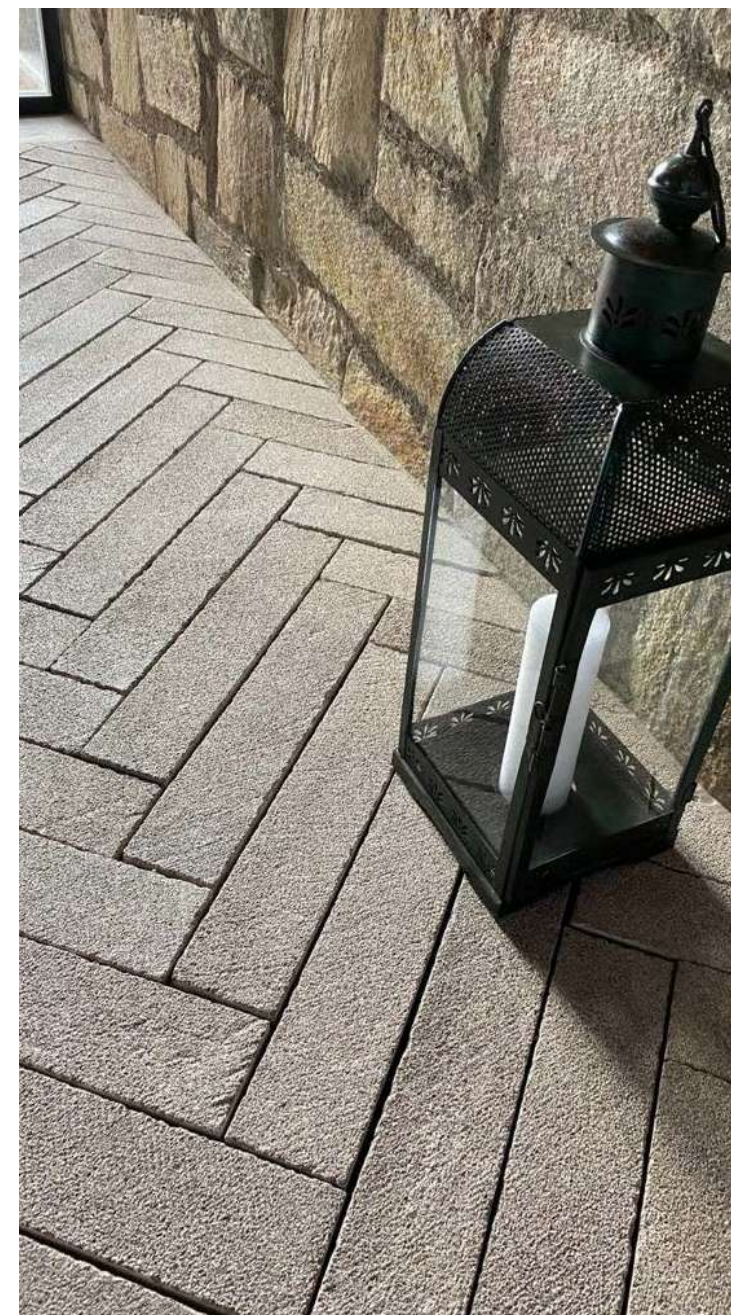

Las losetas Basaltex son elementos prefabricados de alta calidad a base de concreto que integra arenas de basalto, arenas de andesita y otros agregados gruesos. Sus dimensiones son variables y contamos con amplia gama de colores y texturas. Se fabrican con revenimiento cero en una sola capa integral o en dos capas, con una tolerancia máxima de 5 mm. El espesor podrá ser variable de acuerdo a las condiciones y tolerancias de cada obra.

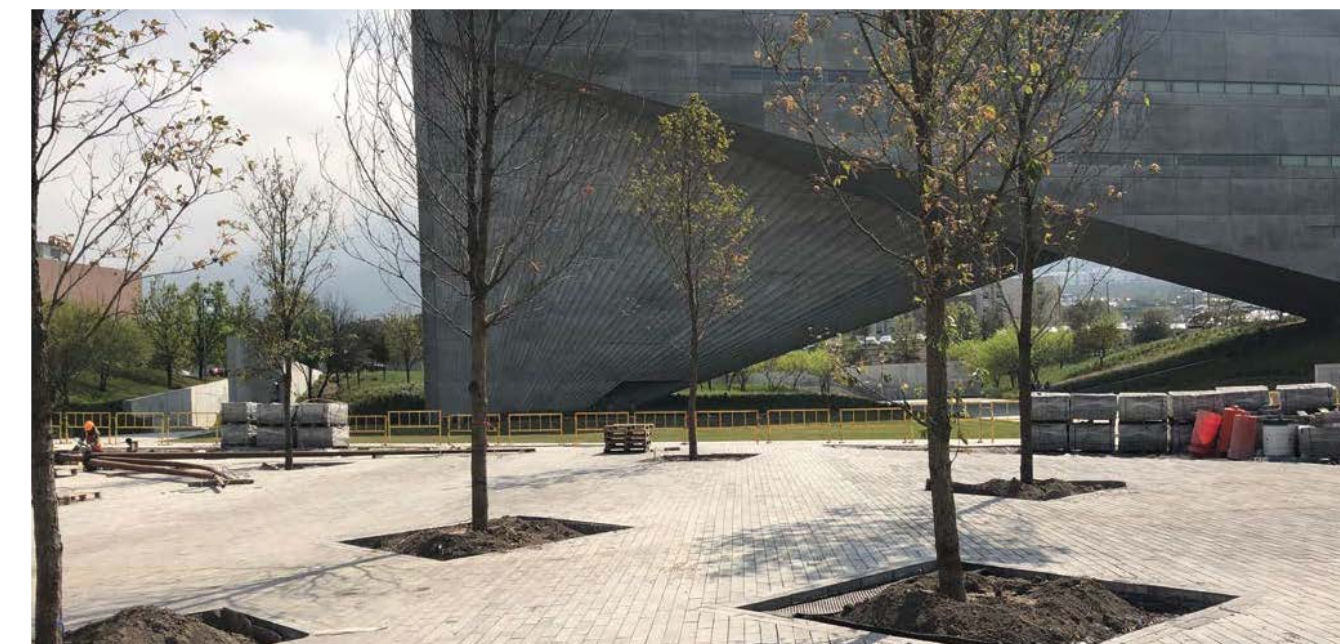

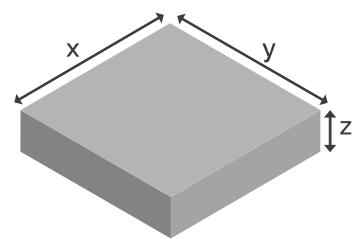

LOSETAS CUADRADAS

Medida (xyz)	10 x 10 x 4 cm	15 x 15 x 4 cm	20 x 20 x 4 cm
Peso (m ² aprox.)	88 kg	88 kg	88 kg
Piezas (en 1m ²)	100 pzas	44 pzas	25 pzas

OTROS ESPESORES

Espesor (z)	5 cm	6 cm	8 cm
Peso (m ² aprox.)	110 kg	132 kg	180 kg

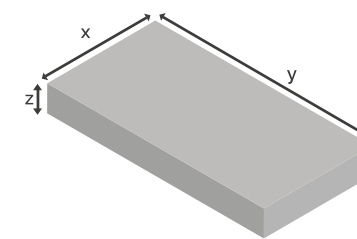

LOSETAS RECTANGULARES*

Medida (xyz)	10 x 40 x 7 cm
Únicamente en 7 cm de espesor	
	5 x 20 x 5 cm
	5 x 20 x 7 cm

ROZANA MONTIEL - ESTUDIO DE ARQUITECTURA
 PILARES PRESIDENTES DE MÉXICO
 FOTOGRAFIA: SANDRA PEREZNIETO



LOSAS

Las Losas Basaltex son de mayor formato y fabricadas en dos capas. La capa superior tendrá un acabado liso o con textura y amplia gama de colores, es de concreto a base de agregados finos de basalto, arenas de andesita y otras, con revenimiento cero. La capa inferior es la que genera gran parte de la resistencia a la compresión, ésta capa está compuesta por agregados gruesos de basalto y arenas de alta calidad. Su acabado (inferior) es rugoso ideal para la adherencia con el mortero de colocación.



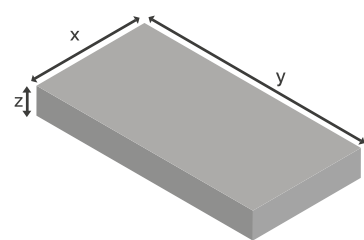
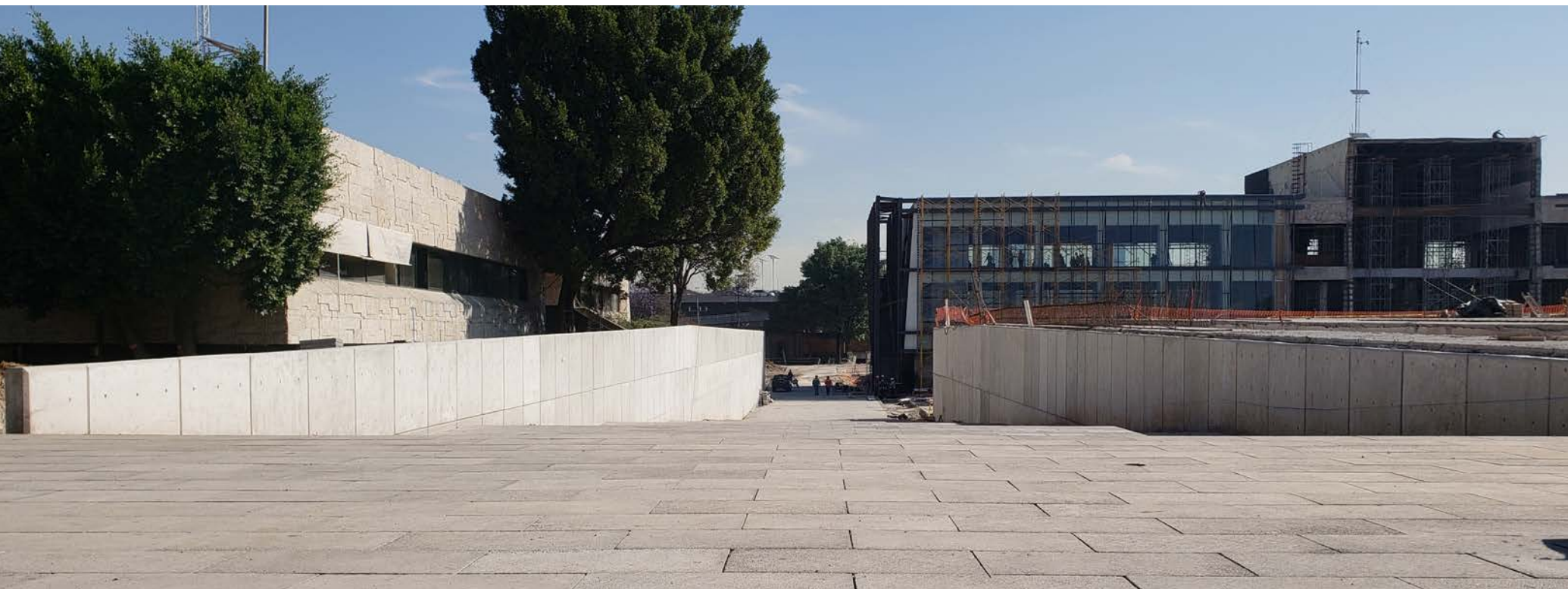

LOSAS RECTANGULARES

Medida (xyz)	10 x 20 x 5 cm	15 x 30 x 4 cm	20 x 60 x 4 cm
Peso (m ² aprox.)	88 kg	88 kg	88 kg
Piezas (en 1m ²)	50 pzas	22 pzas	8.32 pzas

OTROS ESPESORES

Espesor (z)	5 cm	6 cm	8 cm
Peso (m ² aprox.)	110 kg	132 kg	180 kg

OTRAS MEDIDAS

15 x 60 cm
 20 x 45 cm
 30 x 90 cm
 40 x 80 cm
 25 x 50 cm

LOSAS RECTANGULARES

Medida (xyz)	20 x 40 x 4 cm	40 x 60 x 4 cm	45 x 90 x 5 cm	50 x 100 x 6 cm	30 x 60 x 6 cm
Peso (m ² aprox.)	88 kg	88 kg	110 kg	132 kg	132 kg
Piezas (en 1m ²)	12.5 pzas	4.16 pzas	2.47 pzas	2 pzas	5.50 pzas

OTROS ESPESORES

Espesor (z)	5 cm	6 cm
Peso (m ² aprox.)	110 kg	132 kg

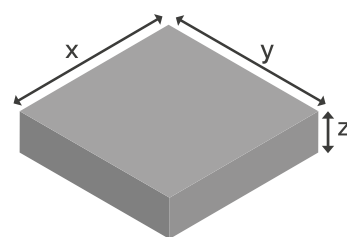

LOSAS CUADRADAS

Medida (xyz)	25 x 25 x 4 cm	30 x 30 x 4 cm	40 x 40 x 4 cm	50 x 50 x 4 cm
Peso (m ² aprox.)	88 kg	88 kg	88 kg	132 kg
Piezas (en 1m ²)	16 pzas	11 pzas	6.25 pzas	4 pzas

OTROS ESPESORES

Espesor (z)	5 cm	6 cm	8 cm
Peso (m ² aprox.)	110 kg	132 kg	180 kg



LOSAS CUADRADAS

Medida (xyz)	60 x 60 x 5 cm	90 x 90 x 5 cm
Peso (m ² aprox.)	110 kg	110 kg
Piezas (en 1m ²)	2.77 pzas	1.24 pzas

OTROS ESPESORES

Espesor (z)	6 cm
Peso (m ² aprox.)	132 kg



CINTILLA



ACRE RESORT, LOS CABOS
FOTOGRAFIA: @ROMANALILIC



CINTILLA

Largo (x)	5 cm	7 cm	10 cm	7 cm
Ancho (y)	30 cm	22 cm	20 cm	30 cm
Espesor (z)	2.54 cm	2.54 cm	2.54 cm	2.5 cm



LOSAS TÁCTILES

Siempre interesados en la solución de estrategias para la movilidad, fabricamos toda la gama de piezas especiales para el diseño universal, guías, cambio de dirección, preventivas, para rampas etc. Las dimensiones, colores y texturas cumplen con las actuales especificaciones normativas en la materia.

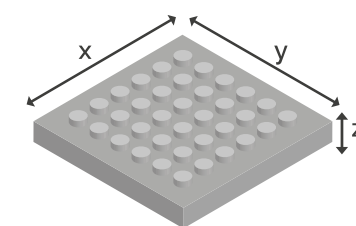
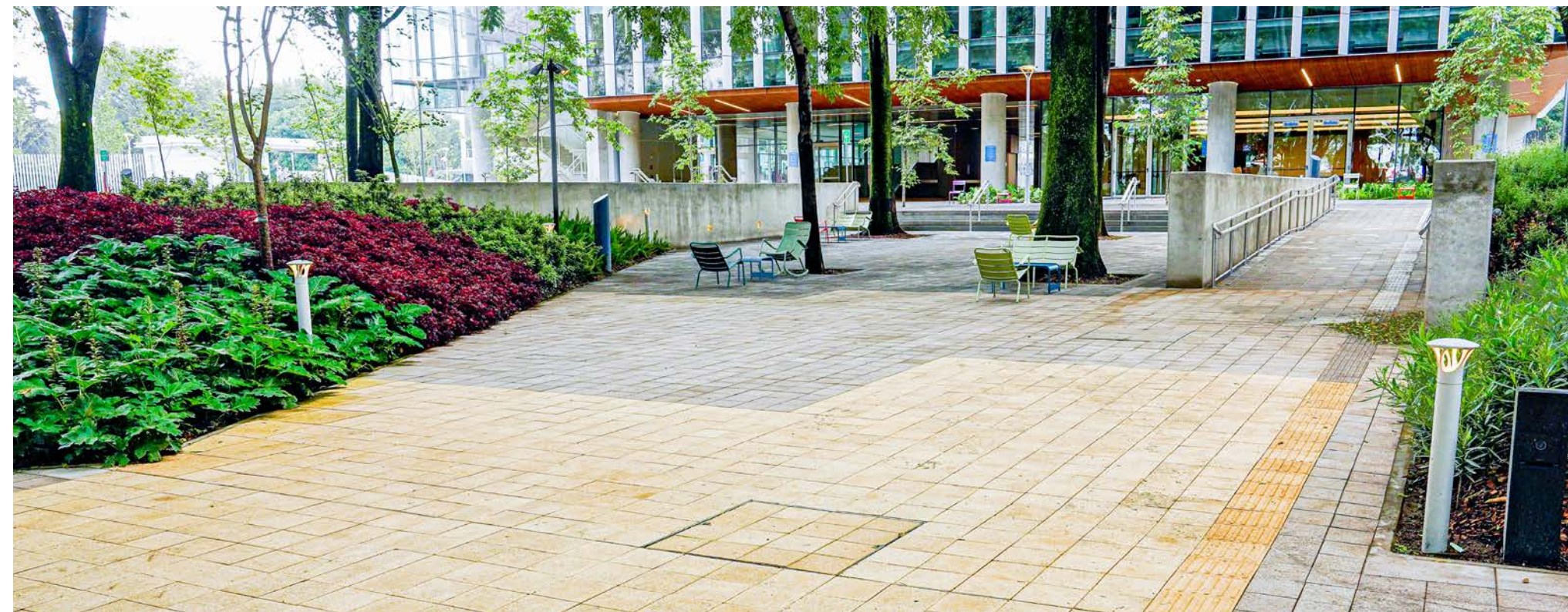

TÁCTIL DE ADVERTENCIA
O CAMBIO DE DIRECCIÓN

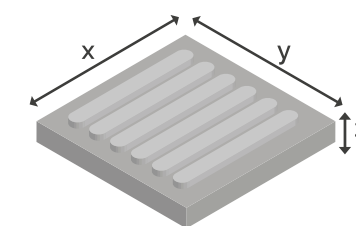

TÁCTIL DE DIRECCIÓN

LOSAS TÁCTILES

	Advertencia	De dirección
Medida (xyz)	30 x 30 x 5 cm 40 x 40 x 5 cm	30 x 30 x 5 cm 40 x 40 x 5 cm
Tamaño de alto relieve	15x 4 mm	27,5 x 25 x 4 mm
Número de conos / barras	36	6
Peso por pieza (en 5cm de espesor)	10 kg	10 kg

CELOSÍAS



PROYECTO: TALLER CARLOS MARÍN + PASQUINEL STUDIO
FOTOGRAFÍA: ONNIS LUQUE

Un elemento original que renace en el lenguaje de diseño contemporáneo, es la creativa gama de celosías Basaltex, su variedad de diseños ha sido conformada por la aportación de distintos y destacados arquitectos, así como diseñadores que incorporan las piezas en sus proyectos.

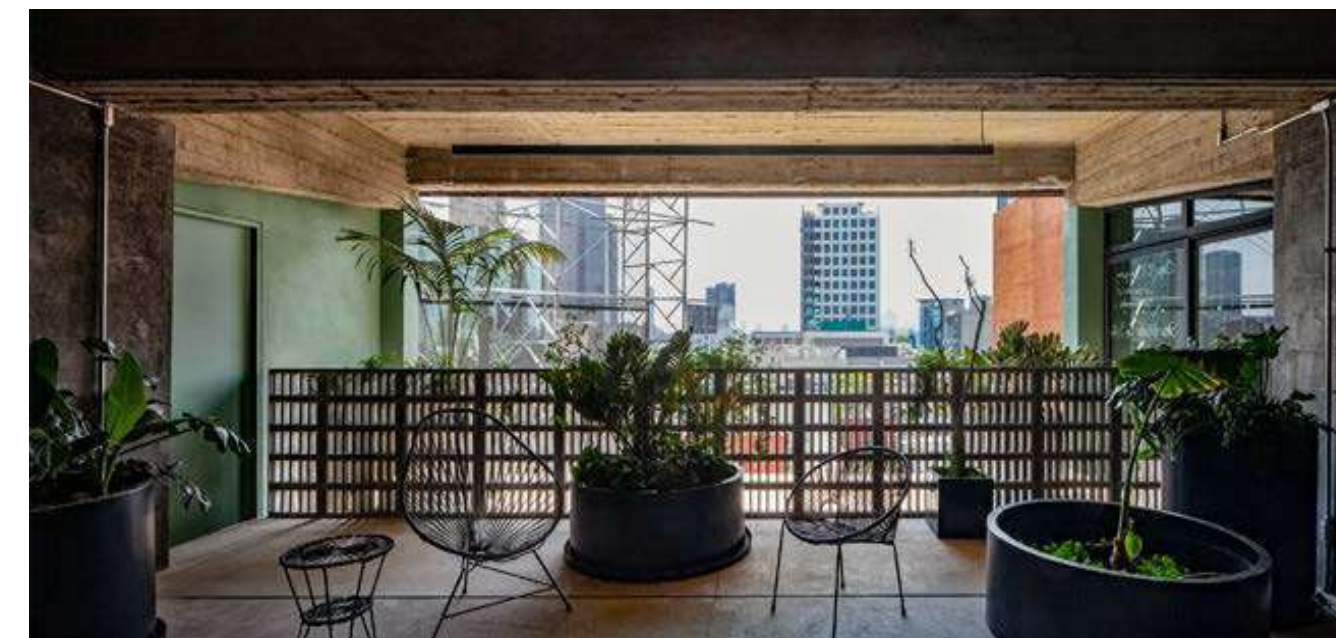

CELOSÍA **ABOCINADA****CELOSÍA ABOCINADA**

Largo (x)	45 cm
Ancho (y)	15 cm
Espesor (z)	8 cm
Piezas por m ²	27 pzas

CELOSÍA **TRM II****CELOSÍA TRM II**

Largo (x)	20 cm
Ancho (y)	75 cm
Espesor (z)	20 cm
Piezas por m ²	25 pzas

CELOSÍA **TRM III****CELOSÍA TRM III**

Largo (x)	19 cm
Ancho (y)	7 cm
Espesor (z)	19 cm
Piezas por m ²	27 pzas

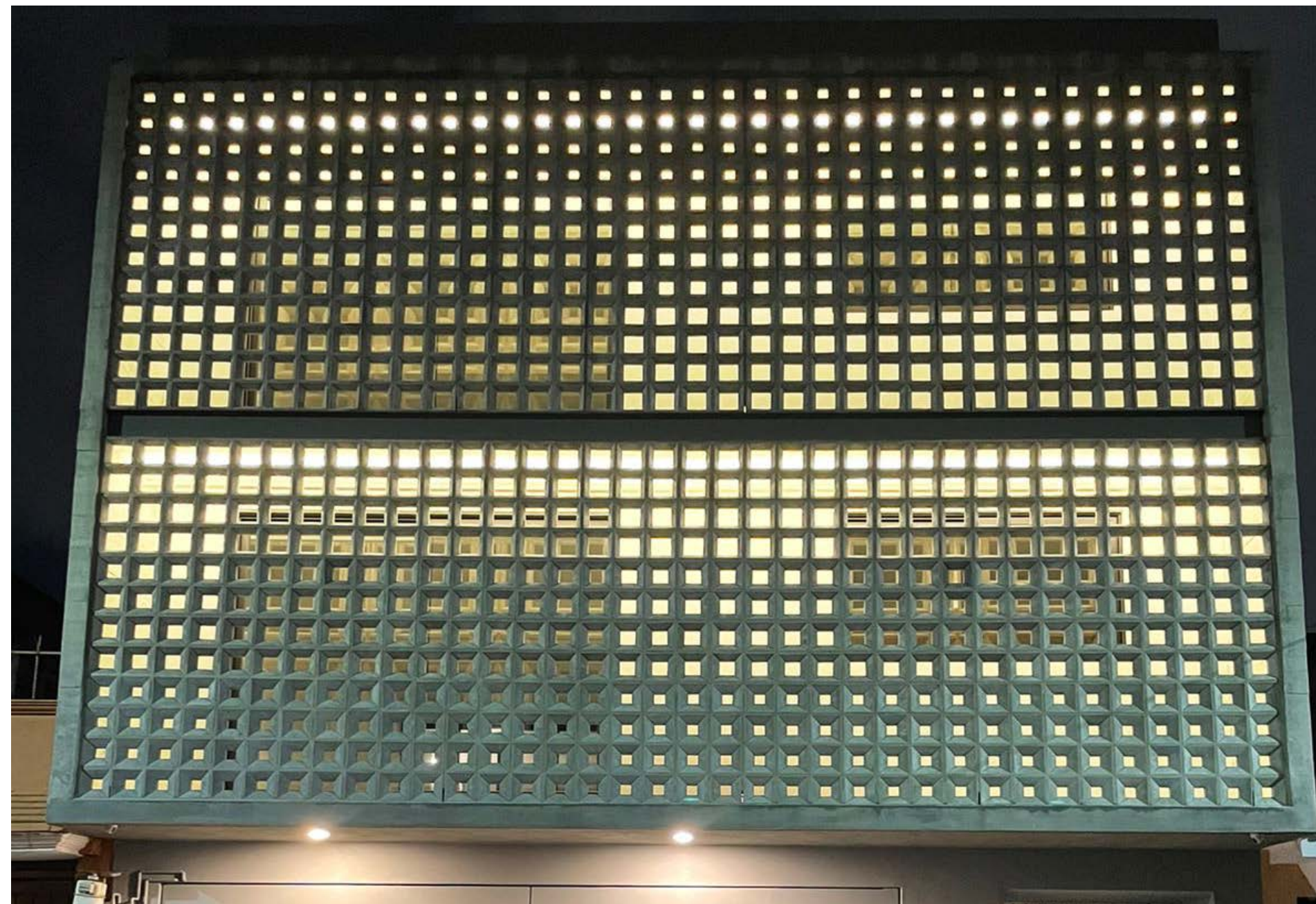



CELOSÍA **AM BAS**

Largo (x)	30 cm
Ancho (y)	12 cm
Espesor (z)	20 cm
Piezas por m ²	16 pzas

CELOSÍA **AM BAS**



CELOSÍA **COLONNIER**

Largo (x)	30 cm
Ancho (y)	10 cm
Espesor (z)	30 cm
Piezas por m ²	11 pzas

CELOSÍA **COLONNIER**

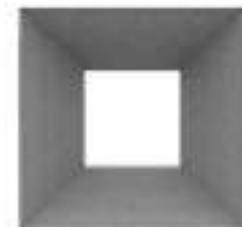

CELOSÍA **DOBLE ABOCINADA**

Largo (x)	20 cm
Ancho (y)	20 cm
Espesor (z)	10 cm
Piezas por m ²	25 pzas

CELOSÍA **DOBLE ABOCINADA**



CELOSÍA **VENTANAS TRIANGULARES**

Largo (x)	40 cm
Ancho (y)	20 cm
Espesor (z)	15 cm

CELOSÍA **VENTANAS TRIANGULARES**

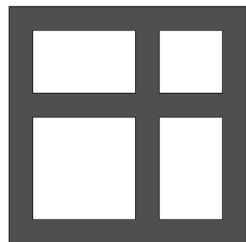
CELOSÍA **DHO****CELOSÍA DHO**

Largo (x)	30 cm
Ancho (y)	30 cm
Espesor (z)	10 cm

CELOSÍA **DIAGONAL****CELOSÍA DIAGONAL**

Largo (x)	25 cm
Ancho (y)	25 cm
Espesor (z)	8 cm

CELOSÍA **DO****CELOSÍA DO**

Largo (x)	30 cm
Ancho (y)	20 cm
Espesor (z)	10 cm

CELOSÍA **LOUVER****CELOSÍA LOUVER**

Largo (x)	20 cm
Ancho (y)	20 cm
Espesor (z)	10 cm

GUARNICIONES



Contamos con gran variedad de diseños de guarniciones, cada una de ellas adecuada según el espacio, uso, imagen y diseño del proyecto. Entre ellas, medio boleó, recta y curva, pecho paloma, tipo achart, etc.



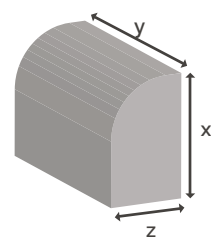

MEDIO BOLEO

Ancho (z)	8 cm
Largo (y)	50 cm
Peralte (x)	20 cm
Peso por pieza (aprox.)	176 kg
Piezas por m lineal	2 pzas

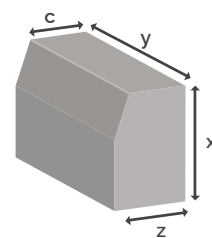

RECTA

Corona (c)	6.5 cm	12 cm	12 cm
Medidas (xyz)	20 x 100 x 8 cm	30 x 100 x 15 cm	40 x 100 x 15 cm
Peso por pieza (aprox.)	36 kg	99 kg	132 kg
Piezas por m lineal	1 pza	1 pza	1 pza



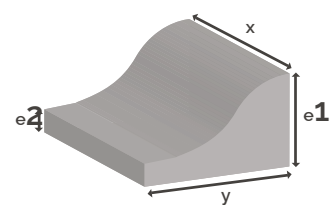

PECHO PALOMA

Largo (x)	40 cm	40 cm	30 cm	30 cm
Ancho (y)	30 cm	60 cm	40 cm	30 cm
Espesor (e1)	20 cm	16 cm	10 cm	15 cm
Espesor (e2)	5 cm	6 cm	5 cm	5 cm
Peso por pieza (aprox.)	34.5 kg	49.8 kg	22 kg	22 kg
Piezas por m lineal	2.5 pzas	2.5 pzas	3.33 pzas	3.33 pzas

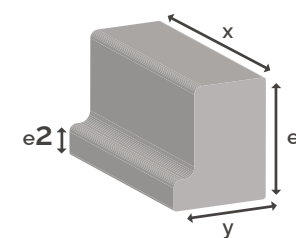

TIPO ACHAT

Largo (x)	60 cm
Ancho (y)	17 cm
Espesor (e1)	17 cm
Espesor (e2)	5.5 cm
Peso por pieza (aprox.)	44 kg
Piezas por m lineal	1.66 pzas

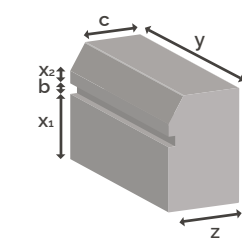

CON CAJILLO O BUÑA

Largo (y)	Variable de 50 a 100 cm
Corona (c)	12 cm
Ancho (z)	15 cm
Espesor (x)	30 cm
Espesor (x1)	20 cm
Cajillo o buña (b)	2 cm
Espesor (x2)	3 cm

HUELLAS Y ESCALONES

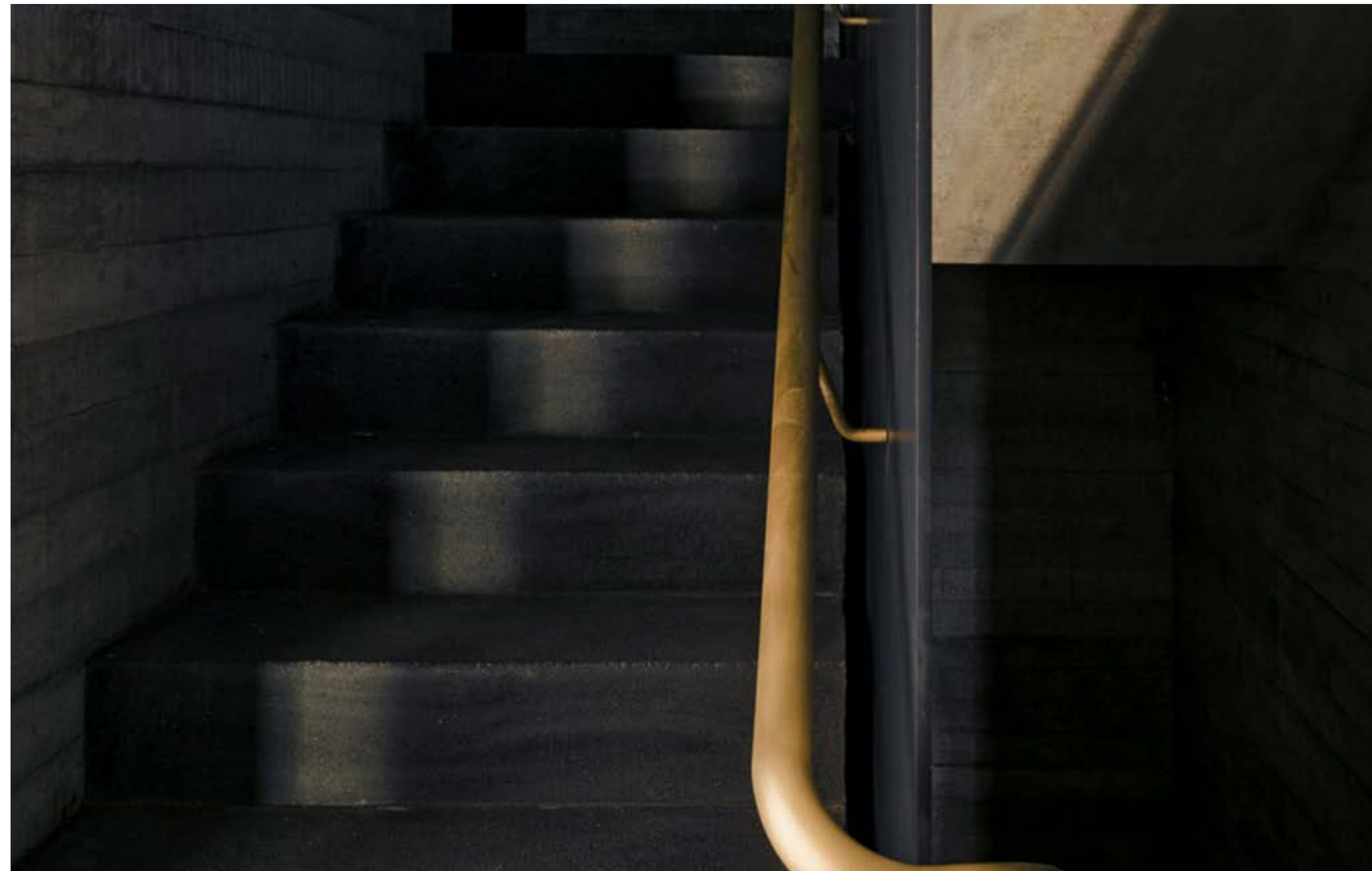

Fabricamos huellas y escalones de acuerdo a las necesidades de cada proyecto, nuestro equipo técnico coadyuva directamente con el cliente o diseñador para definir puntualmente las necesidades o especificaciones.



ESCALONES

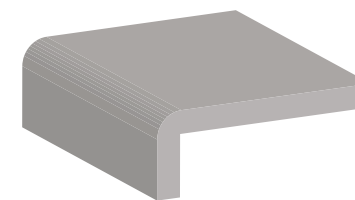
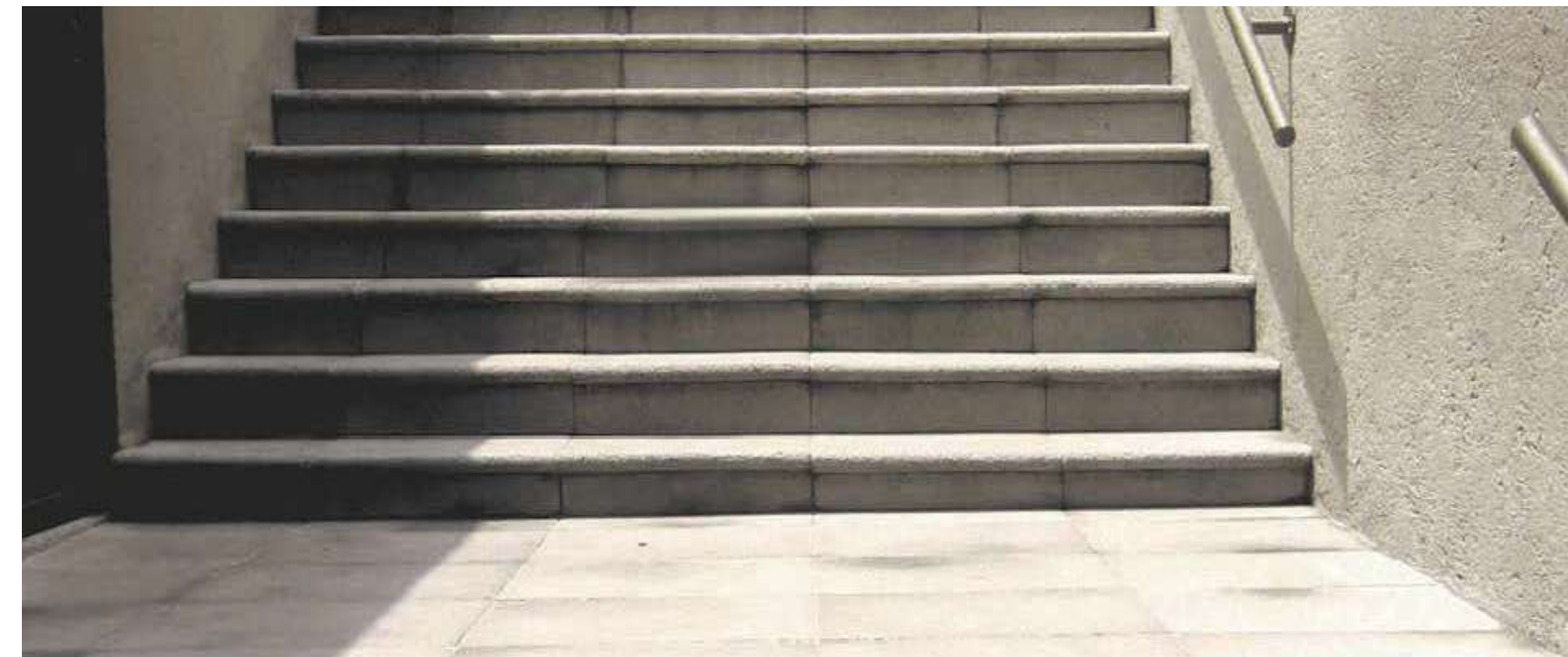
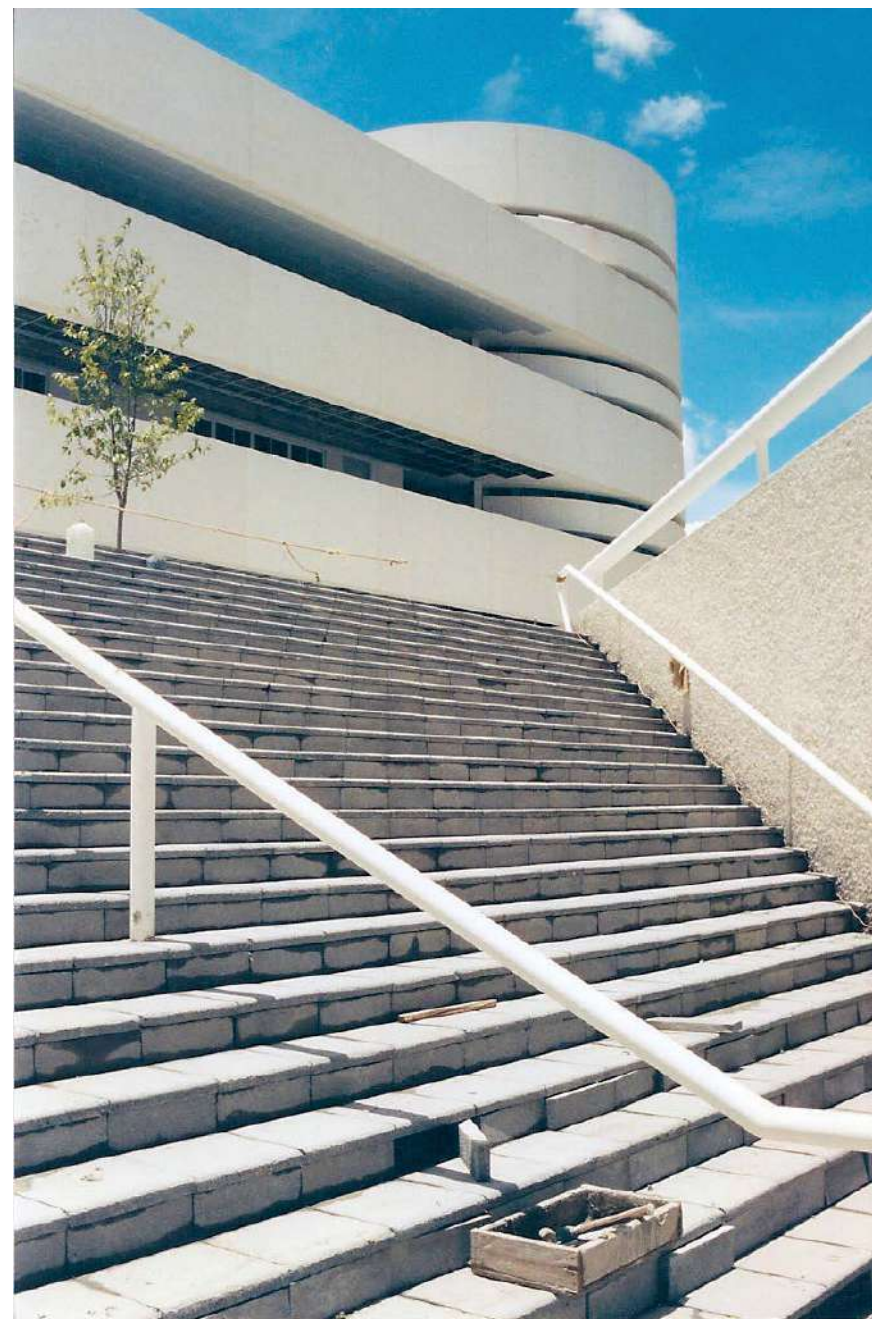

ESCALÓN CON **NARIZ MEDIO BOLEO**

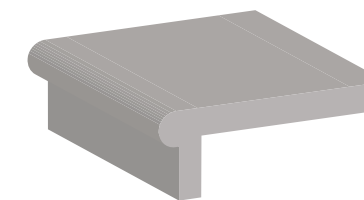

ESCALÓN CON **BOLETO COMPLETO**

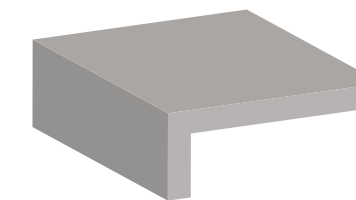

ESCALÓN CON **NARIZ RECTA**

Medidas al gusto del cliente | Espesor mínimo de 4 cm | Longitud máxima de 90 cm.



HUELLAS

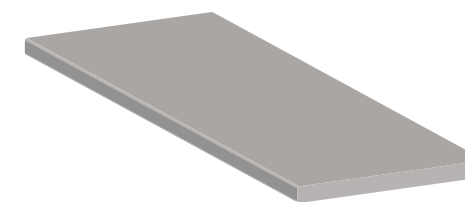

HUELLA CON **BOLEO COMPLETO**

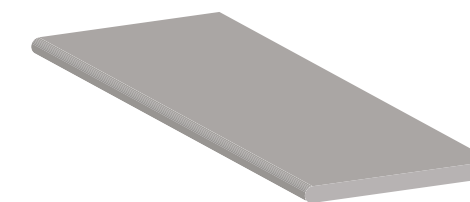

HUELLA CON **NARIZ CHAFLÁN**

Medidas al gusto del cliente | Espesor mínimo de 4 cm | Longitud máxima de 90 cm.



MUEBLES URBANOS

Nuestro catálogo de muebles urbanos fabricados en concreto ofrece diversidad y funcionalidad para su uso de acuerdo a la necesidad de cada espacio. Nuestro equipo técnico y de diseño cuenta con la capacidad, experiencia para resolver el diseño y fabricación del mobiliario.



MUEBLES URBANOS

BANCA TIPO FRISOS

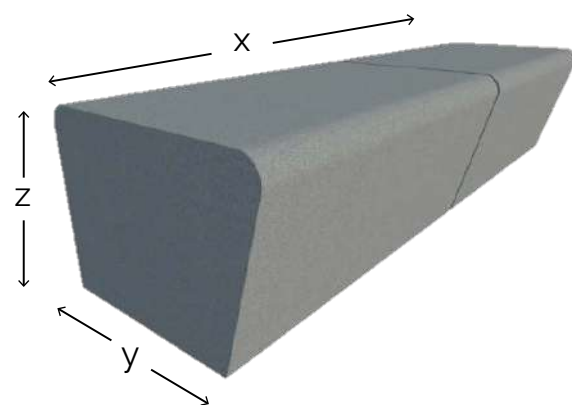

Medida X: 100cm
Medida Y: 60cm
Medida Z: 45cm

CON O SIN RESPALDO

BANCA TIPO GRAPA

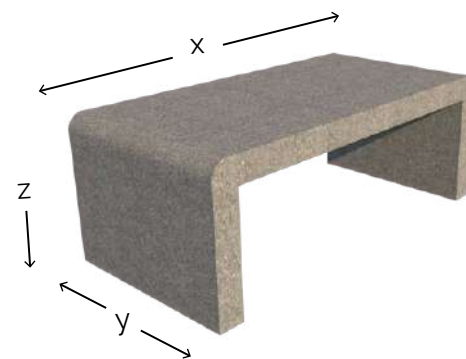

Medida X: 120cm
Medida Y: 60cm
Medida Z: 45cm

BANCA TIPO TRIANGULAR

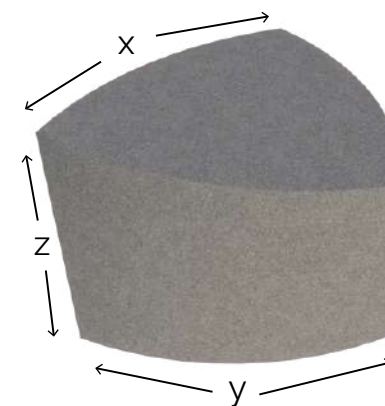

Medida X: 60cm
Medida Y: 60cm
Medida Z: 50 cm

BANCA JARDINERA

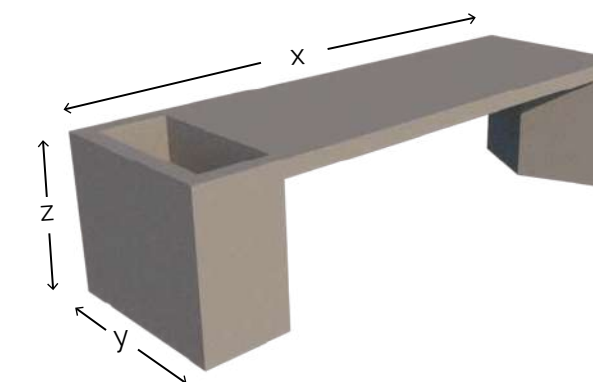

Medida X: 170cm
Medida Y: 55cm
Medida Z: 45cm

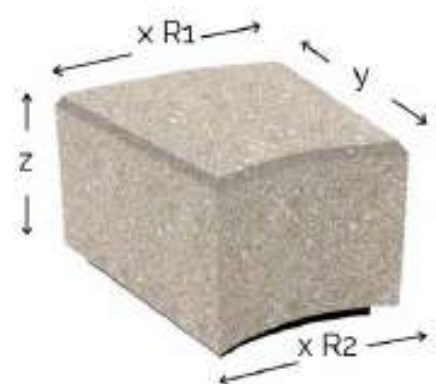

Medida x R1 53 cm
Medida x R2 39 cm
Medida y 57 cm
Medida z 39 cm

BANCA TIPO MUELA

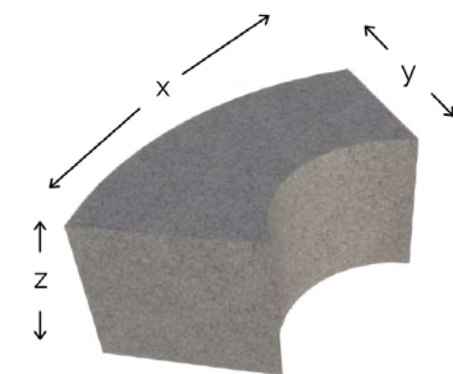

Medida x 98 cm
Medida y 50 cm
Medida z 40 cm

BANCA RADIAL TIPO D

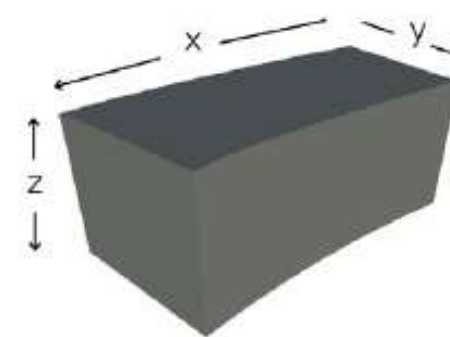

Medida x 102 cm
Medida y 45 cm
Medida z 40 cm

BANCA RADIAL TIPO C

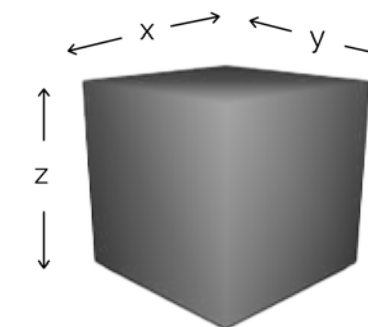

Medida x 50 cm
Medida y 50 cm
Medida z 50 cm

BANCA TIPO CUBO

LONGITUD VARIABLE

**ESFERAS**



PANELES



PANEL ESTRIADO

Largo (x)	60 cm
Ancho (y)	60 cm
Espesor (z)	5 cm

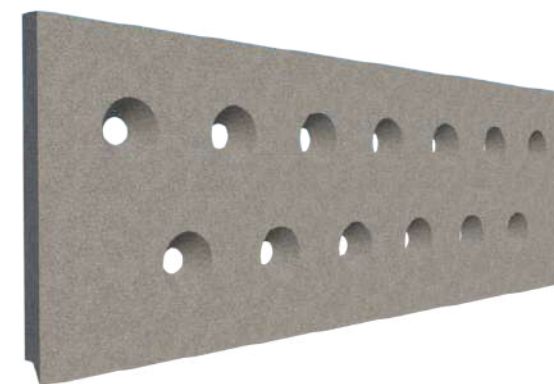

PANEL CON PERFORACIONES CÓNICAS

Largo (x)	150 cm
Ancho (y)	50 cm
Espesor (z)	5 cm



PANEL TIPO VENECIANO

Largo (x)	150 cm
Ancho (y)	50 cm
Espesor (z)	5 cm



IDEAS EN CONCRETO



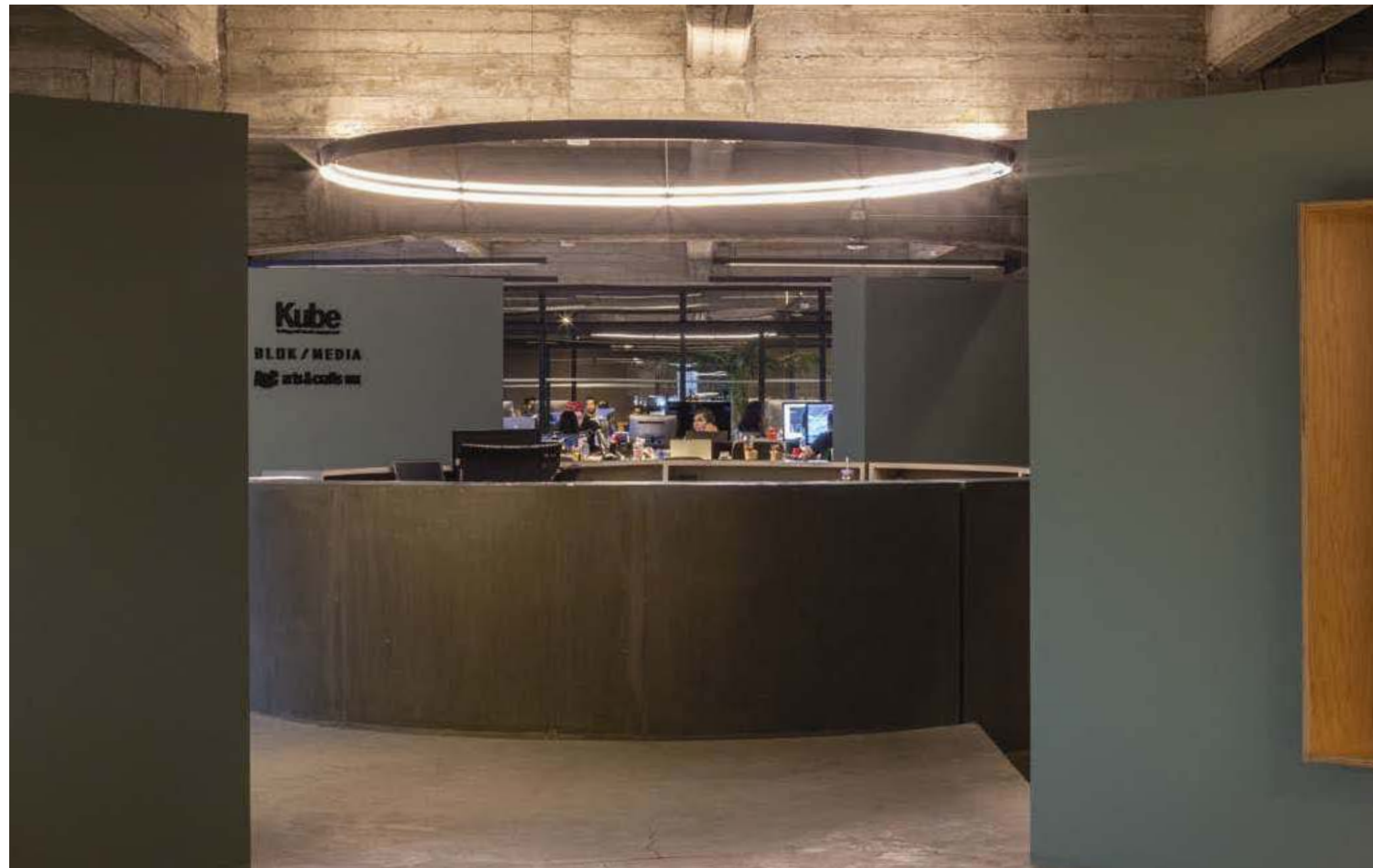

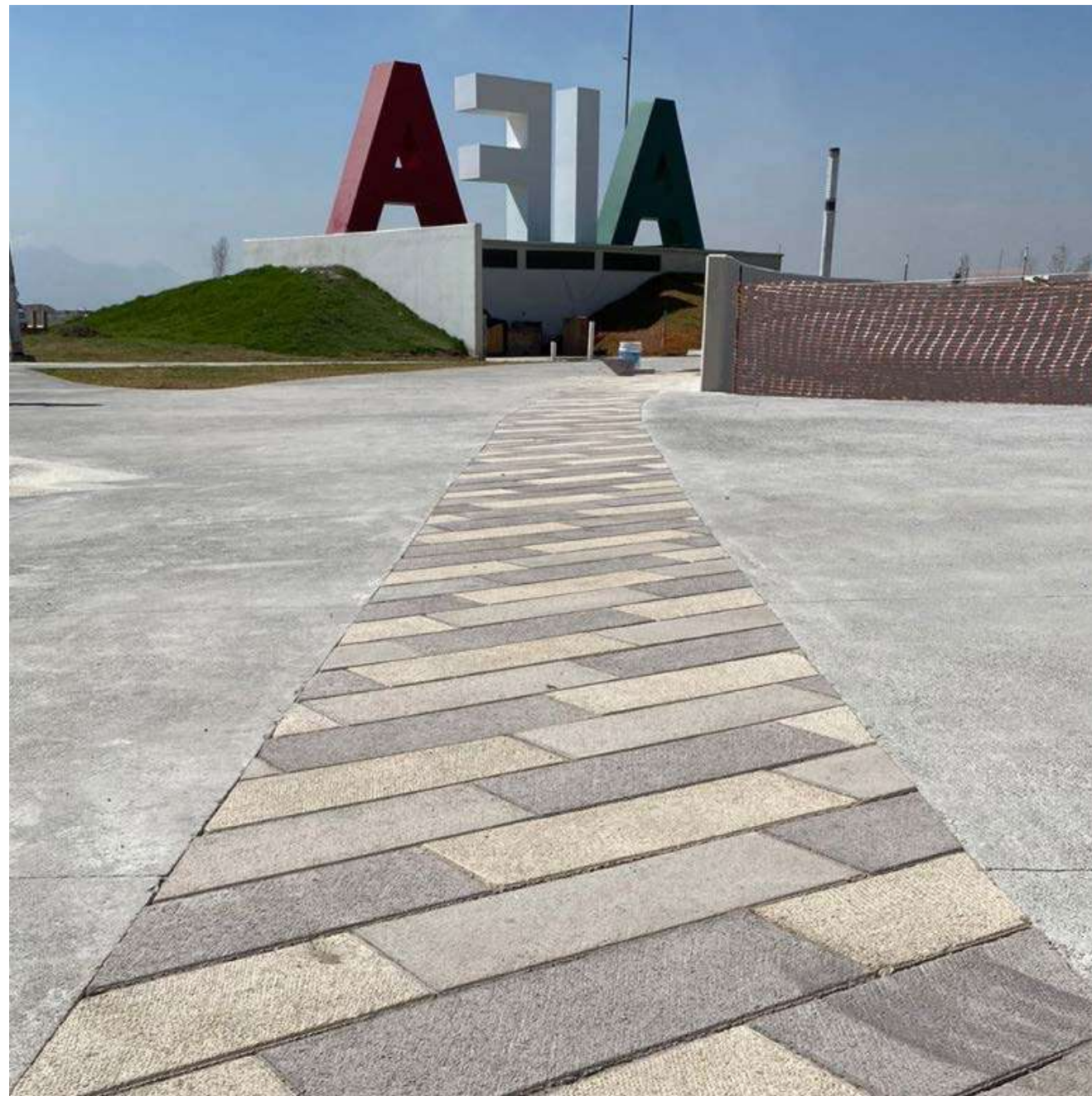

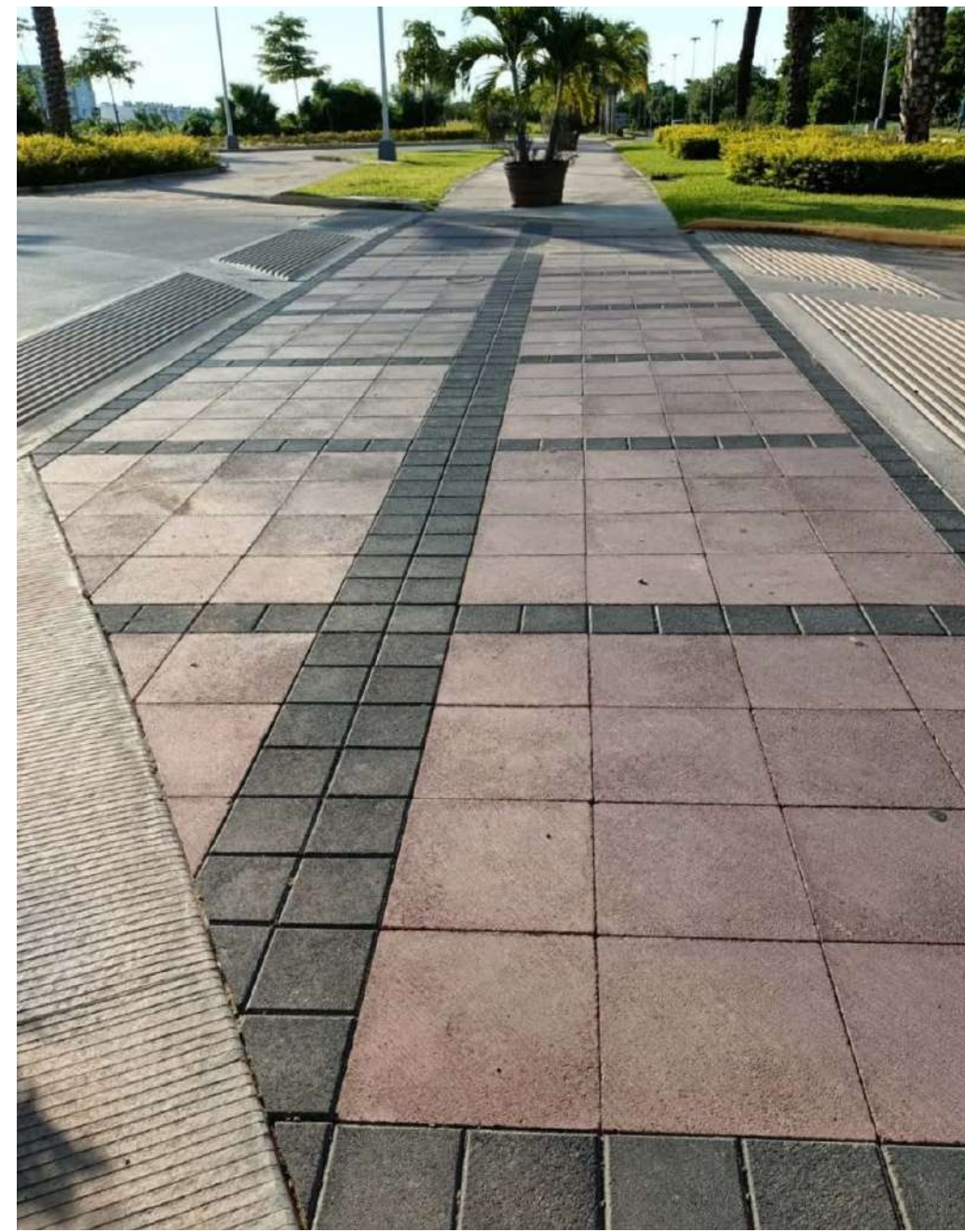

ADOCRETOS



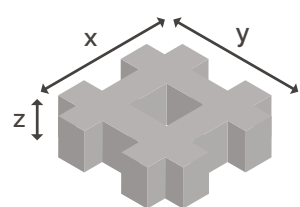

**TIPO HUECO, REJILLA
O GATO**

TIPO HUECO, REJILLA O GATO

Ancho (x)	33 cm	33 cm
Largo (y)	33 cm	33 cm
Espesor (z)	6 cm	8 cm
Largo (m ² aprox.)	121 kg	169.5 kg
Piezas (en 1m ²)	9 pzas	9 pzas

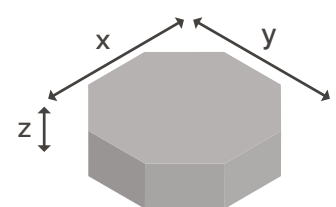

OCTAGONAL

OCTAGONAL

Ancho (x)	24 cm	24 cm
Largo (y)	24 cm	24 cm
Espesor (z)	6 cm	8 cm
Largo (m ² aprox.)	132 kg	180 kg
Piezas (en 1m ²)	16 pzas	16 pzas

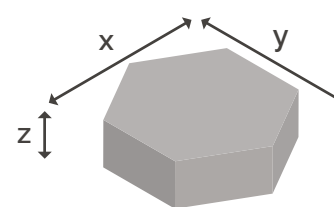

HEXAGONAL

HEXAGONAL

Ancho (x)	18 cm	18 cm
Largo (y)	20 cm	20 cm
Espesor (z)	6 cm	8 cm
Largo (m ² aprox.)	132 kg	180 kg
Piezas (en 1m ²)	35 pzas	35 pzas

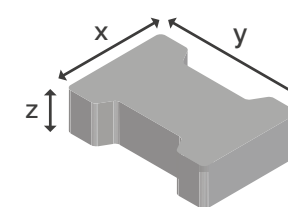

TIPO "I"

TIPO "I"

Ancho (x)	16 cm	16 cm
Largo (y)	20 cm	20 cm
Espesor (z)	6 cm	8 cm
Largo (m ² aprox.)	132 kg	180 kg
Piezas (en 1m ²)	36 pzas	36 pzas

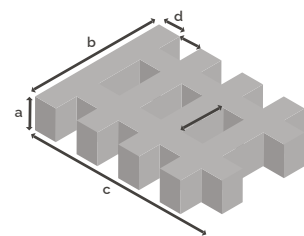

ADOPASTO LINEAL
BISELADO

ADOPASTO LINEAL BISELADO

	A	B	C
Dimensiones	11,5 cm	30 cm	30 cm
Piezas (en 1m ²)	11 pzas		
Peso por pieza	15 kg		
Características	Pieza fabricada marca Basaltex en concreto de alta resistencia,		

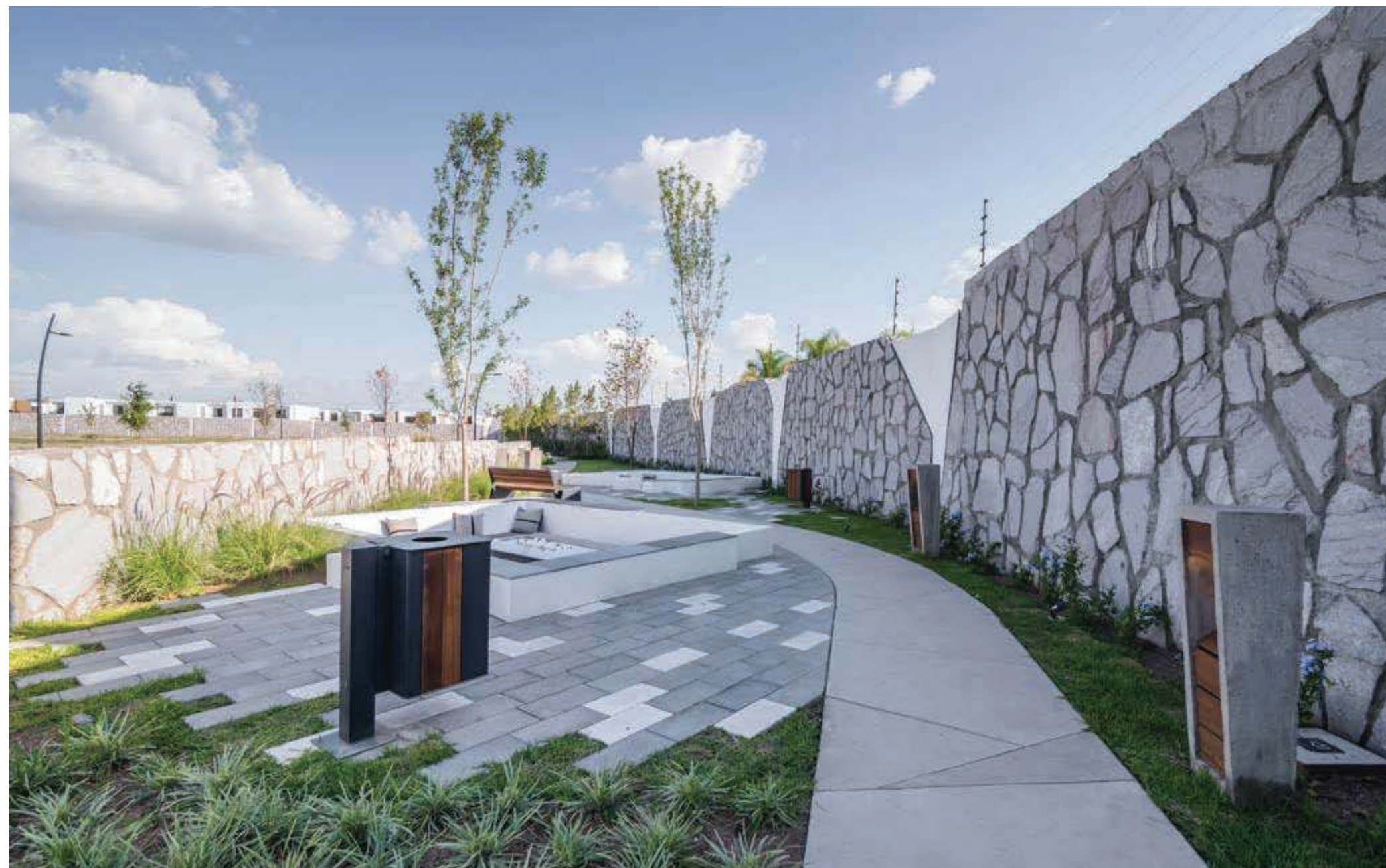

CONTACTO



OFICINAS

(55) 5674 1529
(55) 5674 2019
(55) 5243 2238

MAIL

ventas@basaltex.com.mx

WEB

www.basaltex.com.mx



basaltex.mx



@basaltex.mx



basaltex.mx

48





Basaltex 