



 **SPEED China**

JIANGMEN SPEED STAINLESS STEEL PRODUCT CO., LTD.  
*R&D · Handmade Sink · Drawn Sink · Sink Accessories*

 **SPEED Vietnam**

VIETTA INDUSTRIES (VN) CO., LTD. *Handmade Sink*  
SPEED SINKWARE (VN) CO., LTD. *Drawn Sink*

<https://www.speedsink.com>  
<http://www.speedsinkware.com>  
<https://www.speed-vietnam.com>

Email: [speed@speedsink.com](mailto:speed@speedsink.com)

# SPEED 20 Years

To be the strongest handmade sink factory in China.



Brand new advanced in-house PVD production line

More color options, more reliability, more possibilities

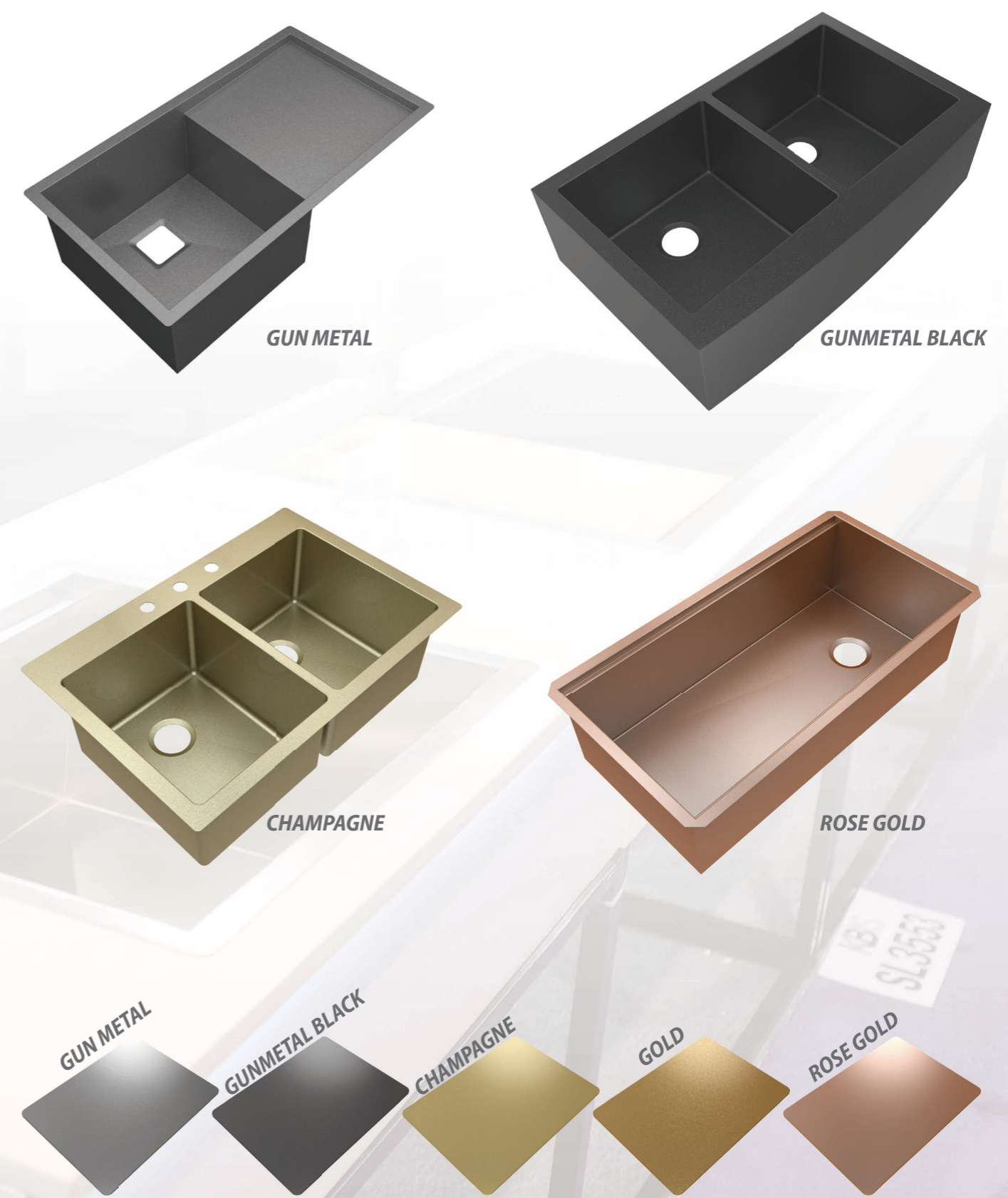

※ The color shown above is for reference only, please contact our sales to get accurate color card.

## 2023 PVD & Nano

Set up a brand new advanced in-house PVD & Nano production line

Provide more color options, more reliability, more possibilities.

## 2018 Drawn sink

Set up a drawn sink production line in China, aiming at Europe, South Aisa and local market.

## 2015 Invested in Vietnam

Set up a drawn sink factory (SPEED sinkware Co., Ltd) in Tay Ninh, Vietnam

exported 100,000 drawn sinks in the first year.

## 2012 KBIS Show

Attended the kitchen and bath international show for the 1st time in Chicago.

## 2004 Company Established

Mr. Raymond Weng set up a small workshop in Jiangmen with about 10 employees,

started producing kitchen sink strainers.



## Future

To be the strongest kitchen sink factory.

## 2021 Vietnam Factories Expanded

Expanded SPEED sinkware Co., Ltd to triple size.

Set up a new handmade sink factory (VIETTA Co., Ltd.) in Vietnam.

The total monthly production capacity reached 100,000 units.

## 2016 China Factory Expanded

Set up the 3rd handmade sink production line in China,

Total monthly capacity reached 50,000 handmade sinks.

## 2012 Cooperation

Set up the 2nd handmade sink production line.

Started cooperating with retailer stores and several key brand companies in the North America Market.

## 2005 Handmade Sink

Started producing handmade sinks for the U.S. Market, shipped 100 sinks in the first 2 months.

# Undermount



## R0/R6R0/R10/R15/R25

- ♦US1618 16"x18"x9" (406.4x457.2x228.6)
- ♦US2318 23"x18"x9" (584.2x457.2x228.6)
- ♦US3018 30"x18"x10" (762x457.2x254)
- ♦US3219 32"x19"x10" (812.8x482.6x254)

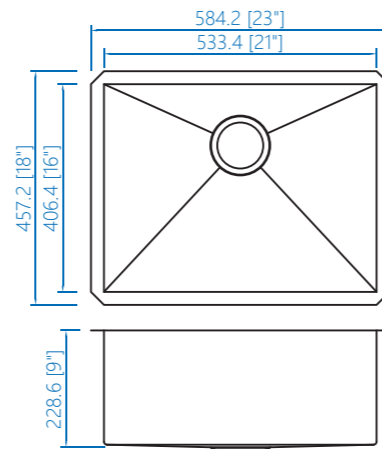

## R0/R6R0/R10/R15/R25

- ♦UD3018A 30"x18"x10" (762x457.2x254)-50/50
- ♦UD3018C 30"x18"x10" (762x457.2x254)-60/40
- ♦UD3219A 32"x19"x10" (812.8x482.6x254)-50/50
- ♦UD3219C 32"x19"x10" (812.8x482.6x254)-70/30

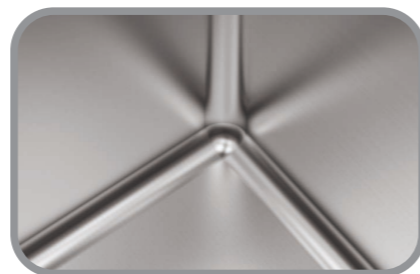
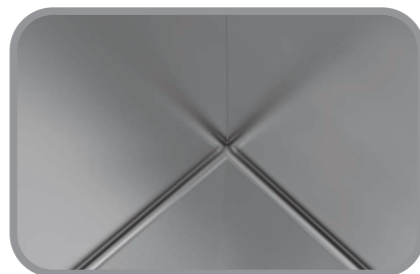
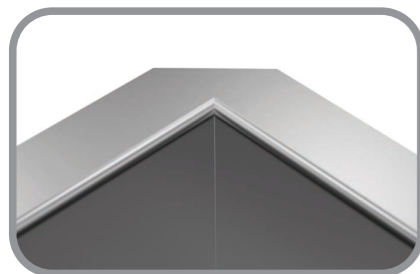
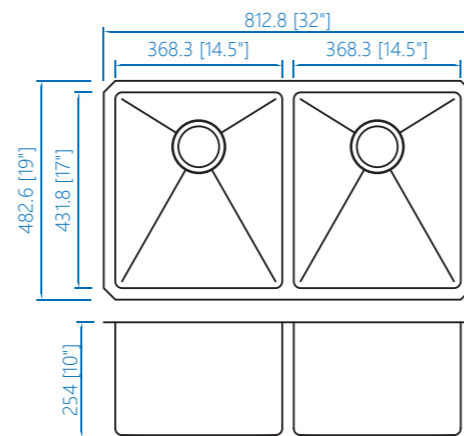

# Topmount



## R0/R6R0/R10/R15/R25

- ♦TS2522 25"x22"x10" (635x558.8x254)
- ♦TS3322 33"x22"x10" (838.2x558.8x254)
- ♦TS2121 21"x21"x9" (533.4x533.4x228.6)
- ♦TS3121 31"x21"x9" (787.4x533.4x228.6)

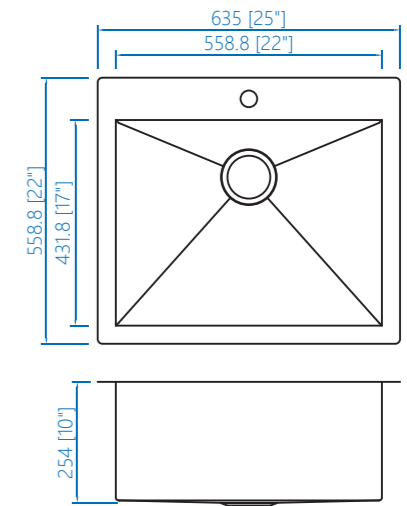
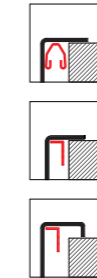

## R0/R6R0/R10/R15/R25

- ♦TD3322A 33"x22"x10" (838.2x558.8x254)-50/50
- ♦TD3322B 33"x22"x10" (838.2x558.8x254)-60/40
- ♦TD3121A 31"x21"x9" (787.4x533.4x228.6)-50/50
- ♦TD3121B 31"x21"x9" (787.4x533.4x228.6)-60/40

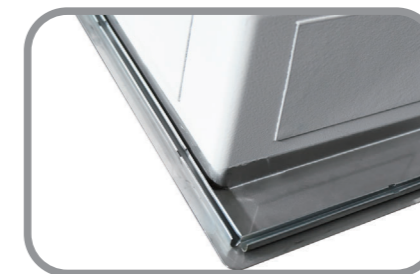
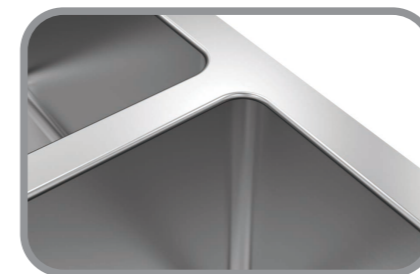
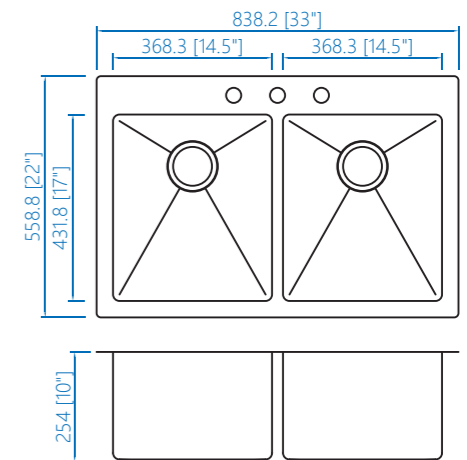
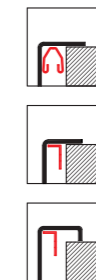

# Workstation - Undermount



## R0/R6R0/R10

- ◆US2419L 24"x19"x10" (609.6x482.6x254)
- ◆US3019L 30"x19"x10" (762x482.6x254)
- ◆US3219L 32"x19"x10" (812.8x482.6x254)

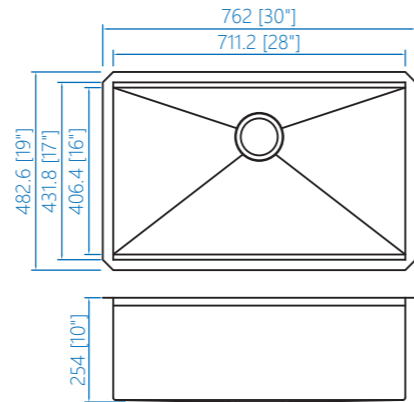

## R0/R6R0/R10

- ◆US3219LA 32"x19"x10" (812.8x482.6x254)-50/50
- ◆US3219LB 32"x19"x10" (812.8x482.6x254)-60/40

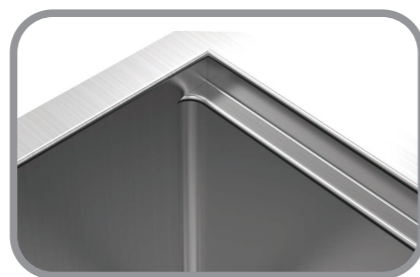
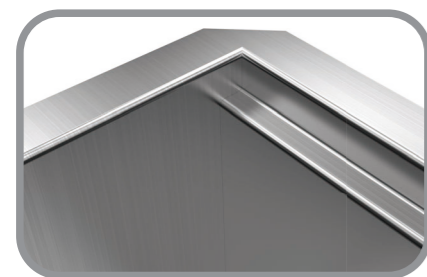
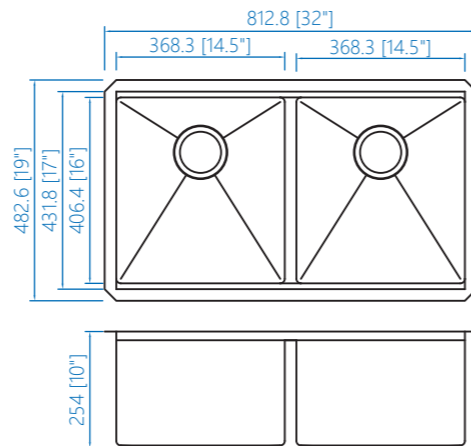

# Workstation - Topmount



## R0/R6R0/R10

- ◆TS2522L 25"x22"x10" (635x558.8x254)
- ◆TS3322L 33"x22"x10" (838.2x558.8x254)

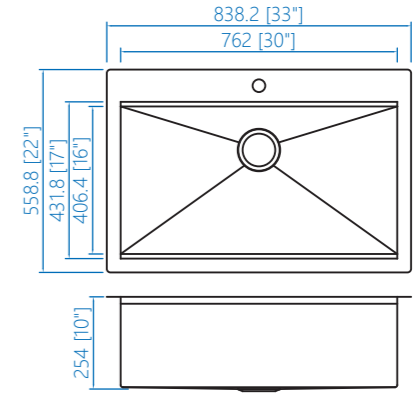
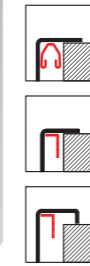

## R0/R6R0/R10

- ◆TS3322LA 33"x22"x10" (838.2x558.8x254)-50/50
- ◆TS3322LB 33"x22"x10" (838.2x558.8x254)-60/40

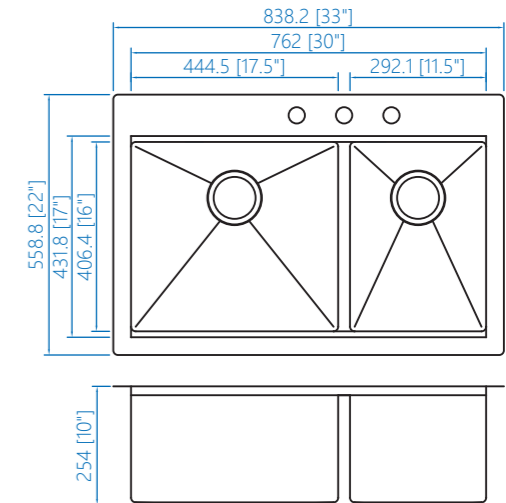
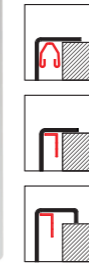

# Workstation - Extra

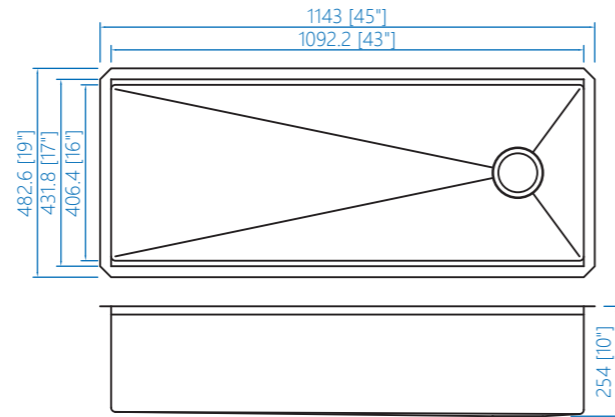

### R0/R6R0/R10

- ◆US3619L 36"x19"x10" (914.4x482.6x254)
- ◆US4019L 40"x19"x10" (1016x482.6x254)
- ◆US4219L 42"x19"x10" (1066.8x482.6x254)
- ◆US4519L 45"x19"x10" (1143x482.6x254)

## Optional Accessories

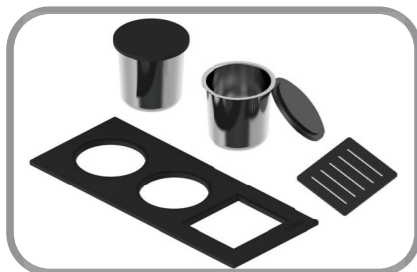
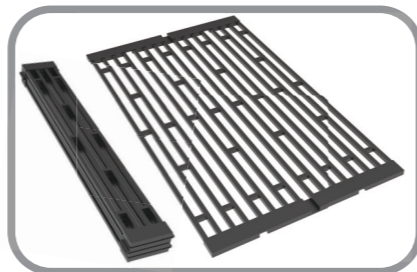
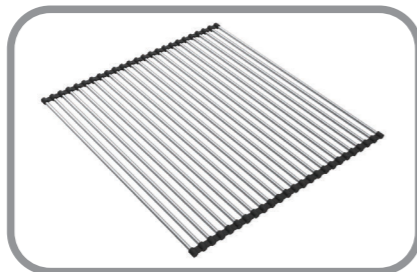
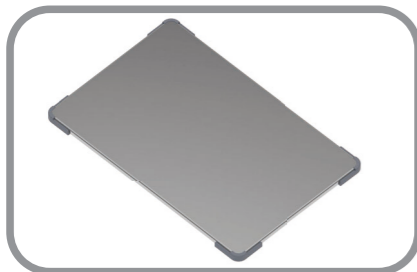

# Farmhouse



### R0/R6R0/R10/R15

- ◆US2722F 27"x22"x10" (685.8x558.8x254)
- ◆US3022F 30"x22"x10" (762x558.8x254)
- ◆US3322F 33"x22"x10" (838.2x558.8x254)
- ◆US3622F 36"x22"x10" (914.4x558.8x254)

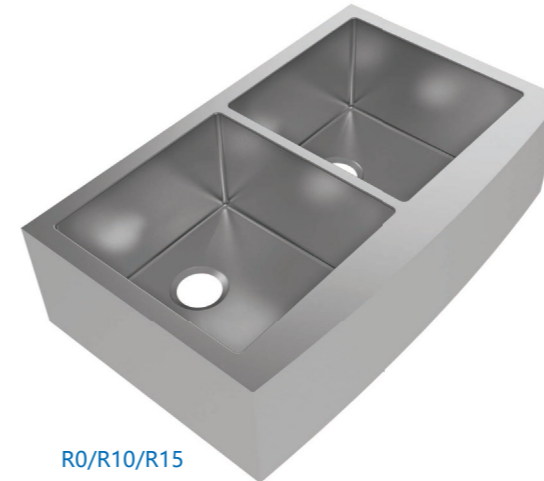
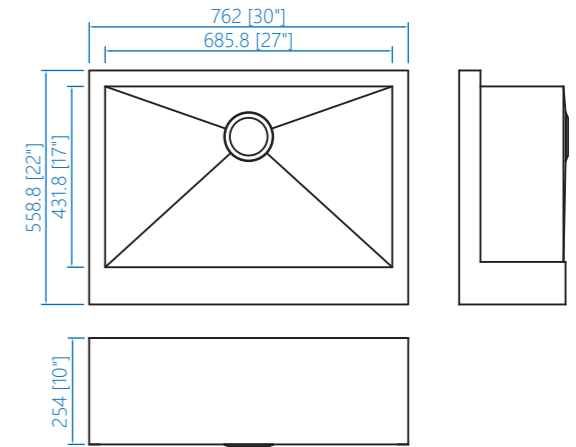

### R0/R10/R15

- ◆UD3322FA 33"x22"x10" (838.2x558.8x254)-50/50
- ◆UD3322FB 33"x22"x10" (838.2x4558.8x254)-60/40
- ◆UD3622FA 36"x22"x10" (914.4x558.8x254)-50/50
- ◆UD3622FB 36"x22"x10" (914.4x558.8x254)-60/40

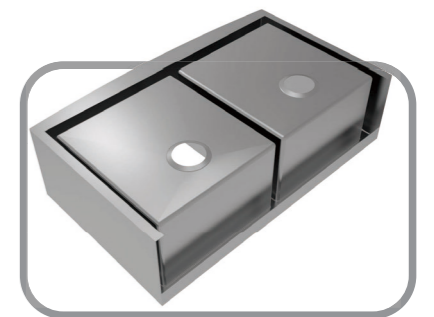
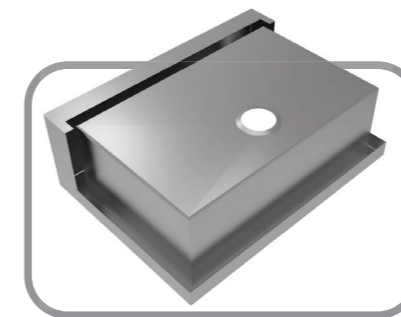
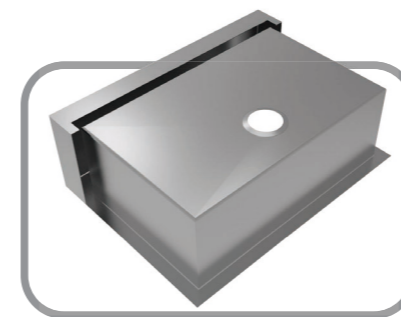
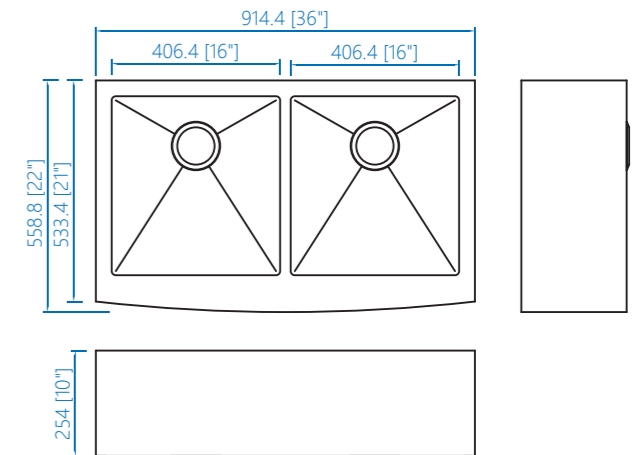

# Low Devide



## R0/R10/R15

- ◆UD3018WA 30"x18"x10" (762x457.2x254)-50/50
- ◆UD3018WC 30"x18"x10" (762x457.2x254)-60/40
- ◆UD3219WA 32"x19"x10" (812.8x482.6x254)-50/50
- ◆UD3219WC 32"x19"x10" (812.8x482.6x254)-60/40

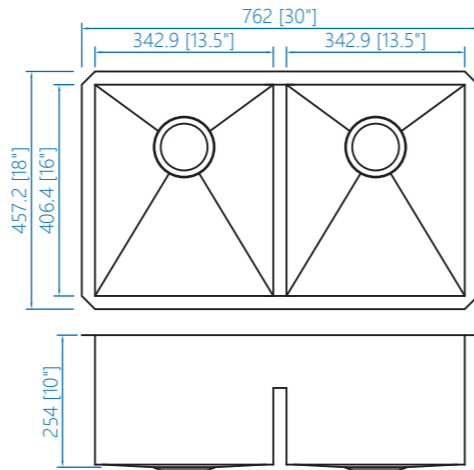

## R0/R10/R15

- ◆UD3018LWA 30"x18"x10" (762x457.2x254)-50/50
- ◆UD3018LWC 30"x18"x10" (762x457.2x254)-60/40
- ◆UD3219LWA 32"x19"x10" (812.8x482.6x254)-50/50
- ◆UD3219LWC 32"x19"x10" (812.8x482.6x254)-60/40

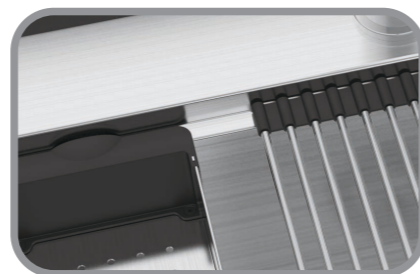
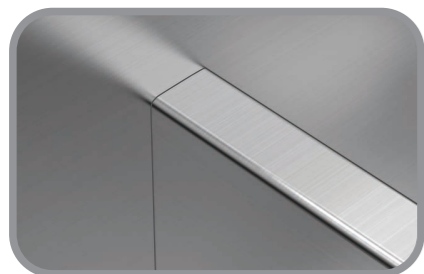
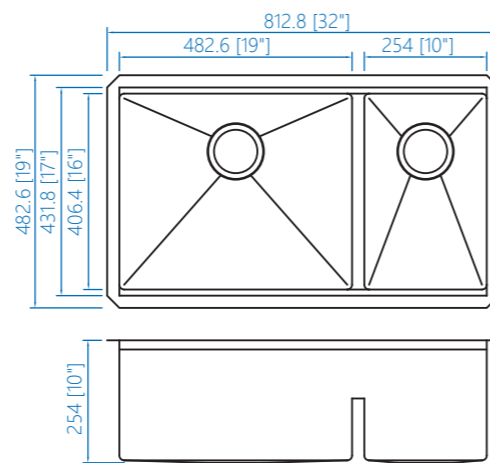

# Sink with Drainerboard

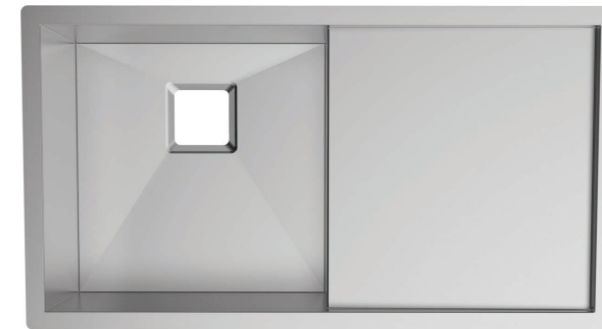

## R0/R10/R15

- ◆US2818D 28"x18"x9" (711.2x457.2x228.6)
- ◆US3018D 30"x18"x10" (762x457.2x254)
- ◆US3318D 33"x18"x10" (838.2x457.2x254)
- ◆US3619D 36"x19"x10" (914.4x482.6x254)

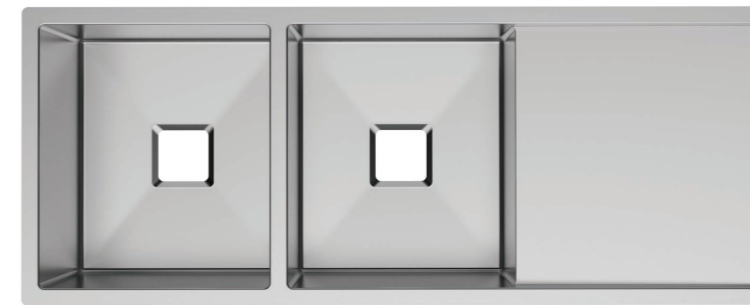
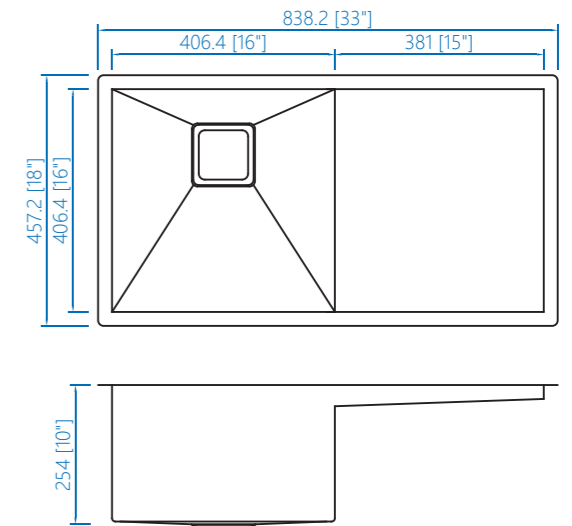

## R0/R10/R15

- ◆UD4518D 45"x18"x10" (1143x457.2x254)
- ◆UD4818D 48"x18"x10" (1219.2x457.2x254)
- ◆UD5219D 52"x19"x10" (1320.8x482.6x254)

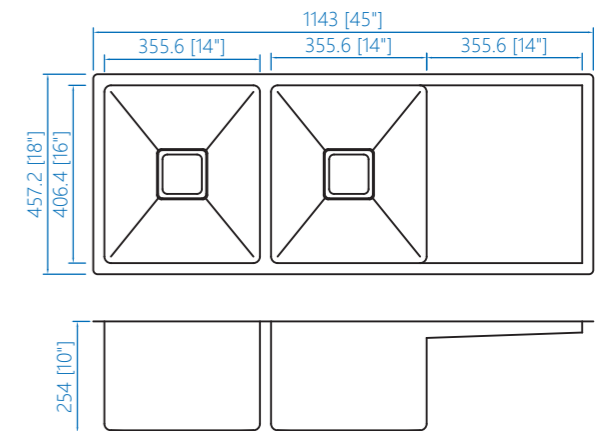

# Low Deck

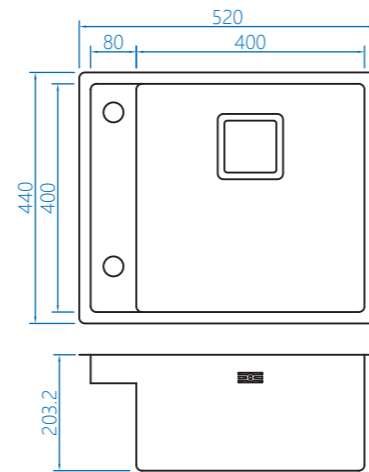

R0/R6R0/R10

- ◆370x440x203.2
- ◆520x440x203.2
- ◆570x440x203.2

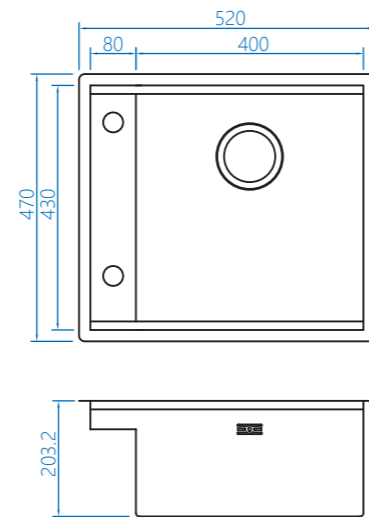

R0/R6R0/R10

- ◆370x440x203.2
- ◆520x440x203.2
- ◆570x440x203.2



# Corner

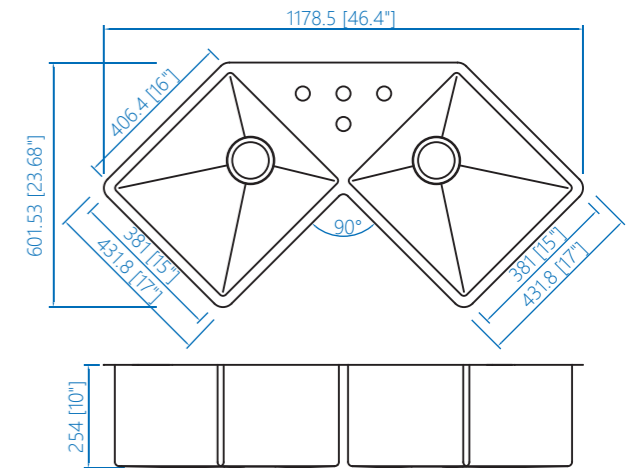
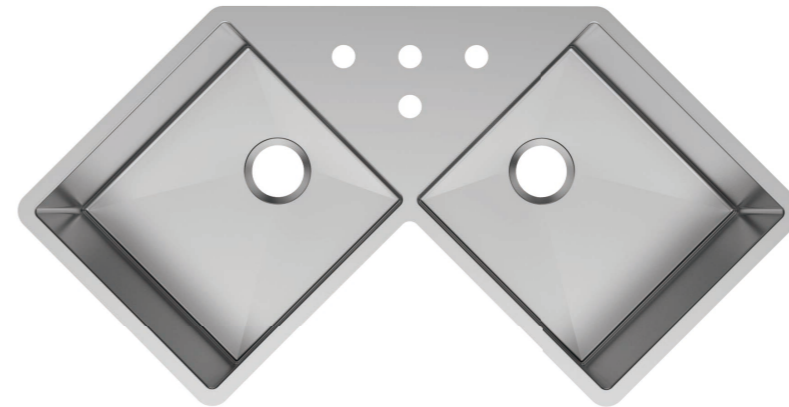

R0/R6R0/R10/R15

- ◆46.4"x23.6"x10" (1178.5x601.5x254)

# Special Shape

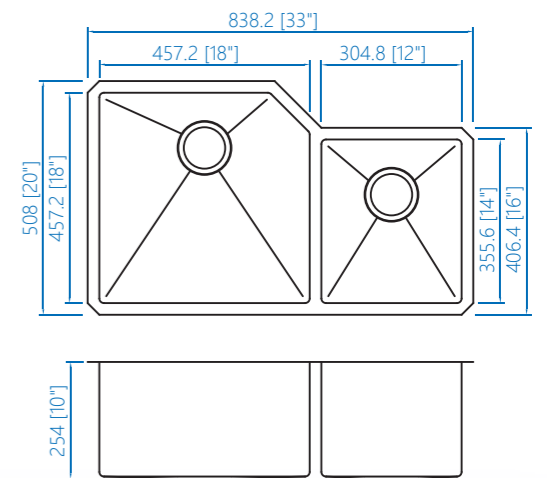

R10/R15

- ◆30"x19"x10" (762x482.6x254)
- ◆33"x20"x10" (838.2x508x254)



## Utility

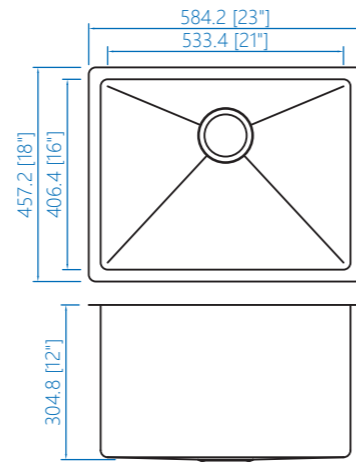

R0/R6R0/R10/R15/R25

- 23"x18"x12" (584.2x457.2x304.8)
- 26"x18"x12" (660.4x457.2x304.8)

## Bowl

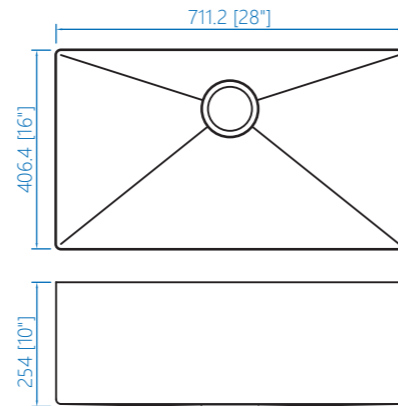

R0/R6R0/R10/R15

- 24"x16"x9" (609.6x406.4x228.6)
- 28"x16"x10" (711.2x406.4x254)
- 30"x16"x10" (762x406.4x254)
- 32"x17"x10" (812.8x431.8x254)

## Workstation - Drainerboard

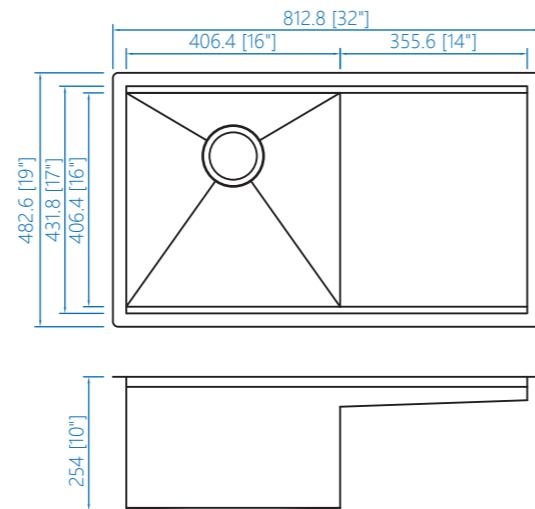

R0

- US2818DL 28"x18"x9" (711.2x457.2x228.6)
- US3019DL 30"x19"x9" (762x482.6x228.6)
- US3219DL 32"x19"x10" (812.8x482.6x254)
- US3619DL 36"x19"x10" (914.4x482.6x254)

## Bar

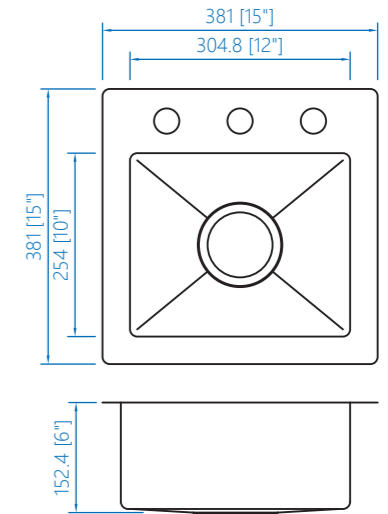
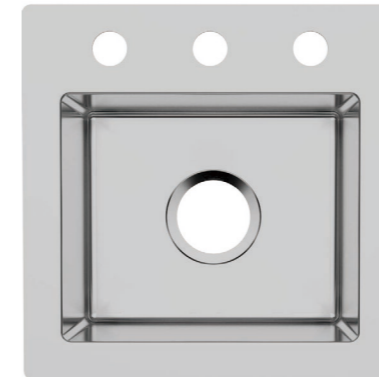

R0/R10/R15

- 15"x15"x6" (381x381x152.4)
- 16"x16"x6" (381x381x152.4)

## Bathroom

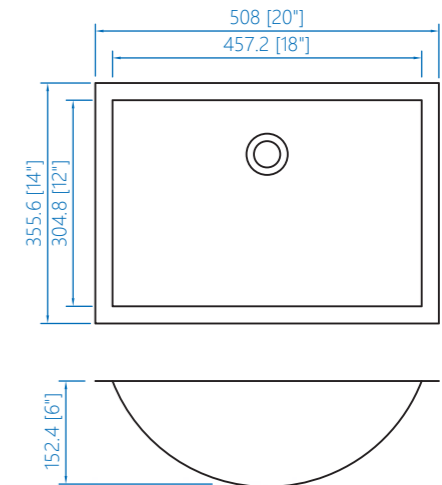

R0

- 14"x10"x6" (355.6x254x152.4)
- 18"x13"x5.5" (457.2x330.2x139.7)
- 20"x14"x6" (508x355.6x152.4)





# Undermount - Basic Line

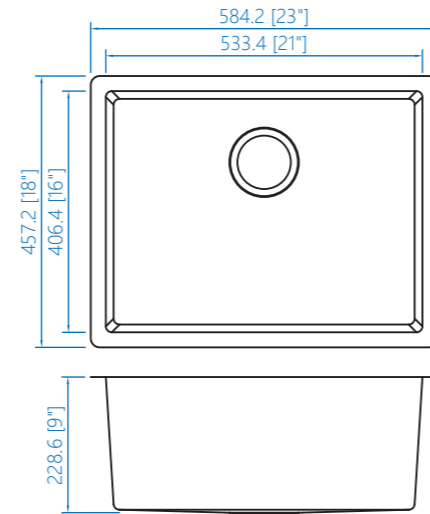

## R10/R15

- ◆US2318C 23"x18"x9" (584.2x457.2x228.6)
- ◆US3018C 30"x18"x9" (762x457.2x228.6)
- ◆US3219C 32"x19"x9" (812.8x482.6x228.6)
- ◆US3319C 33"x19"x9" (838.2x482.6x228.6)

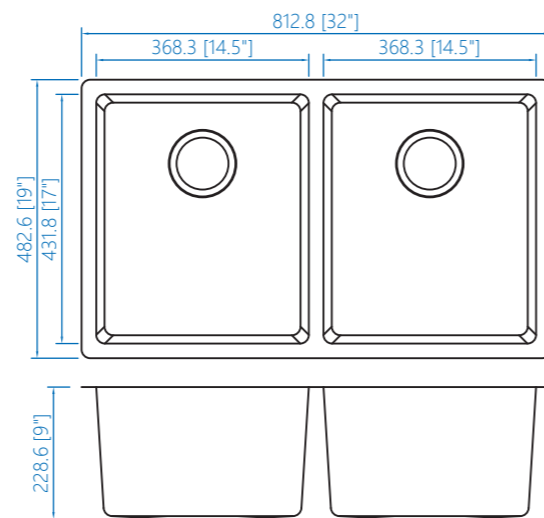

## R10/R15

- ◆UD3018CA 30"x18"x9" (762x457.2x228.6)-50/50
- ◆UD3219CA 32"x19"x9" (812.8x482.6x228.6)-50/50
- ◆UD3219CB 32"x19"x9" (812.8x482.6x228.6)-60/40
- ◆UD3319CA 33"x19"x10" (838.2x482.6x254)-50/50

# Topmount - Basic Line

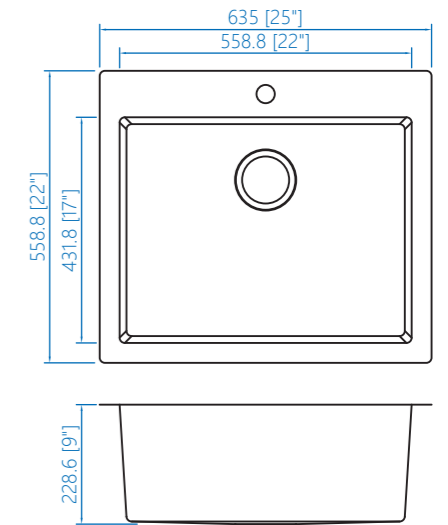

## R10/R15

- ◆TS2522C 25"x22"x9" (635x558.8x228.6)
- ◆TS3322C 33"x22"x9" (838.2x558.8x228.6)
- ◆TS2121C 21"x21"x9" (533.4x533.4x228.6)
- ◆TS3121C 31"x21"x9" (787.4x533.4x228.6)

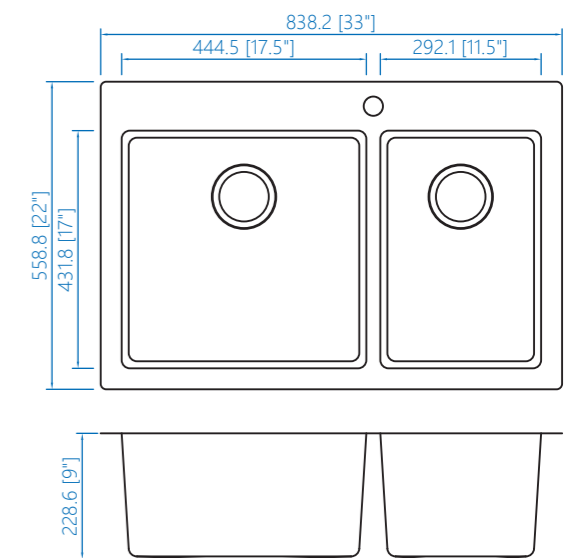

## R10/R15

- ◆TD3322CA 33"x22"x9" (838.2x558.8x228.6)-50/50
- ◆TD3322CB 33"x22"x9" (838.2x558.8x228.6)-60/40
- ◆TD3121CA 31"x21"x9" (787.4x533.4x228.6)-50/50
- ◆TD3121CB 31"x21"x9" (787.4x533.4x228.6)-60/40

# RV & VAN

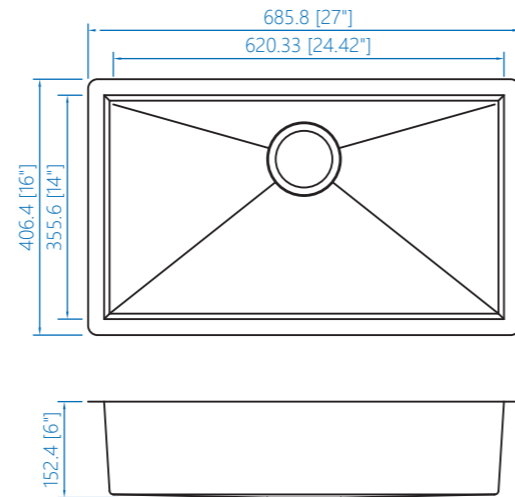

- R0/R10/R15**
- ◆16"x16"x6" (406.4x406.4x152.4)
  - ◆22"x16"x6" (658.8x406.4x152.4)
  - ◆27"x16"x6" (685.8x406.4x152.4)

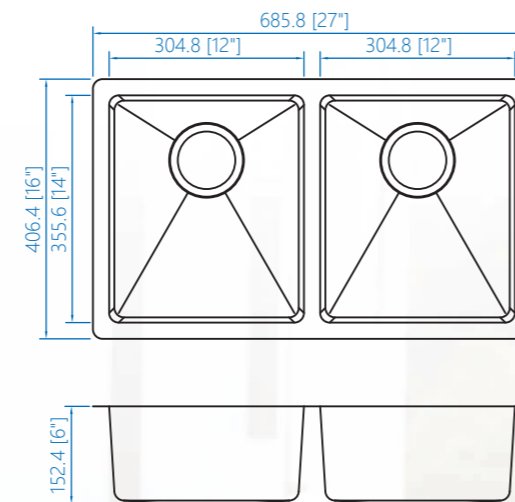

- R0/R10/R15**
- ◆24"x16"x6" (609.6x406.4x152.4)
  - ◆27"x16"x6" (685.8x406.4x152.4)

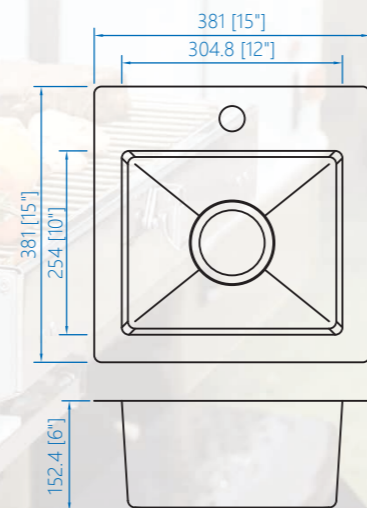

- R0/R10/R15**
- ◆15"x15"x6" (381x381x152.4)
  - ◆16"x16"x6" (406.4x406.4x152.4)

# Shower Niche

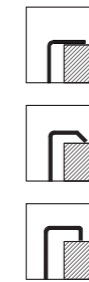

Satin Finish  
Stainless Steel

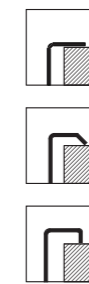
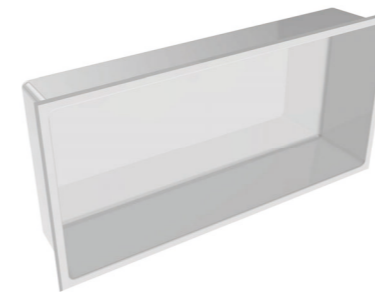

Powder Coating Finish  
White

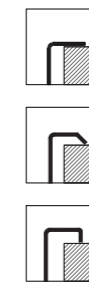

Powder Coating Finish  
Black

- R0/R10**
- ◆TS 1212N 12"x12"x4" (304.8x304.8x101.6)
  - ◆TS 2412N 24"x12"x4" (609.6x304.8x101.6)
  - ◆TS 1224NA 12"x24"x4" (304.8x609.6x101.6)



Satin Finish with PVD and Nano  
Gun metal



Satin Finish with PVD and Nano  
Matte Gold



Satin Finish with PVD and Nano  
Rose Gold

- R0/R10**
- ◆TS 836N 8"x36"x4" (203.2x914.4x101.6)
  - ◆TS 2412NB 24"x12"x4" (609.6x304.8x101.6)
  - ◆TS 3612NA 36"x12"x4" (914.4x304.8x101.6)